



Technology leads Intelligent life

# Technical & Service Manual

## MINI ARV

### DC Inverter T1

ARV-H080/NR1A	ARV-H120/SR1DCS7
ARV-H100/NR1A	ARV-H140/SR1DCS7
ARV-H120/NR1A	ARV-H160/SR1DCS7
ARV-H140/NR1A	ARV-H140/SR1DCSA
ARV-H160/NR1A	ARV-H160/SR1DCSA
ARV-H080/NR1	ARV-H220/SR1DCS7
ARV-H100/NR1	ARV-H260/SR1DCS7
ARV-H120/NR1	ARV-H220/5R1A
ARV-H140/NR1	ARV-H280/5R1A
ARV-H160/NR1	

## CONTENT

<b>Part1 General Information .....</b>	<b>3</b>
<b>Part2 Outdoor Engineering Data.....</b>	<b>8</b>
<b>Part3 Refrigerant Circuit.....</b>	<b>10</b>
<b>Part4 Installation .....</b>	<b>14</b>
<b>Part5 Commissioning .....</b>	<b>14</b>
<b>Part6 Function and Control.....</b>	<b>45</b>
<b>Part7 Trouble shooting .....</b>	<b>50</b>
<b>更新记录表 .....</b>	<b>75</b>

# Part1 General Information

## 1.Product features and benefits

### 1.1 High EER/COP energy saving

High EER/COP means the same capacity but the lower power input, Lower power consumption, lower cost.

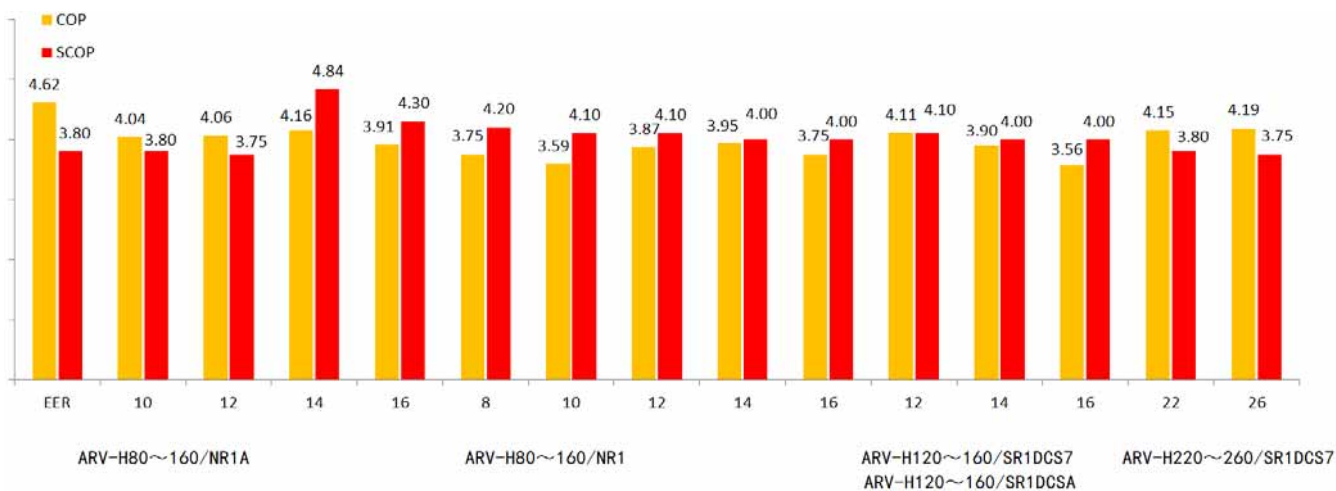
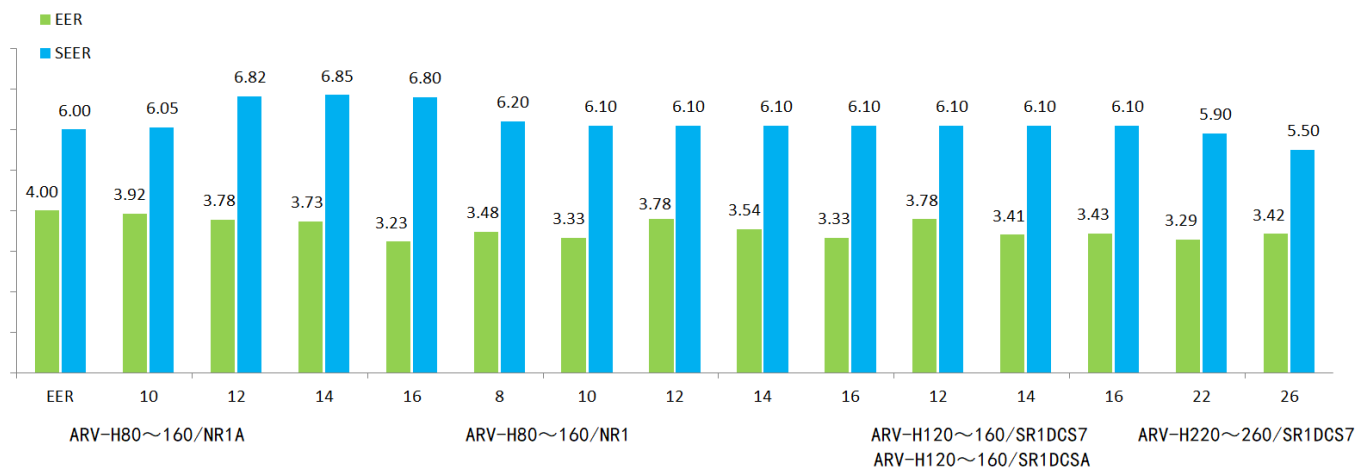

### 1.2 Wide operation range

Operates stably under extreme conditions ranging from - 15 to 49.

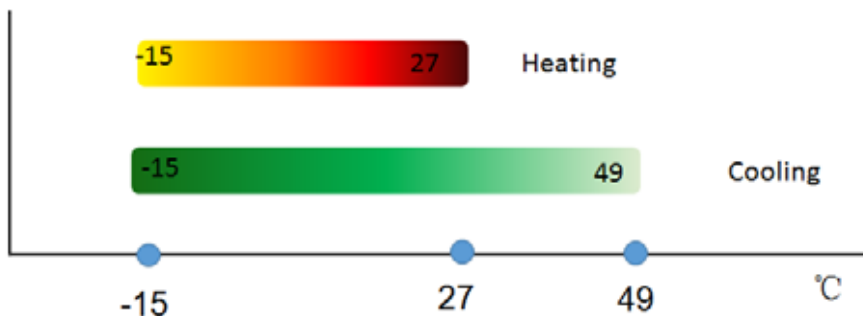

### 1.3 26°C economic locking

All indoor units will run as energy saving mode state.

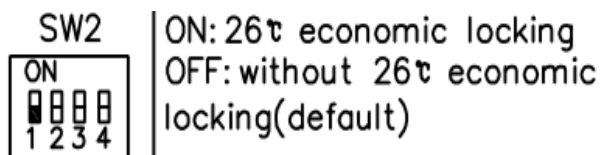

### 1.4 Silent Mode-ODU

About 3 dB reduce than normal mode, Little influence with your neighbors.

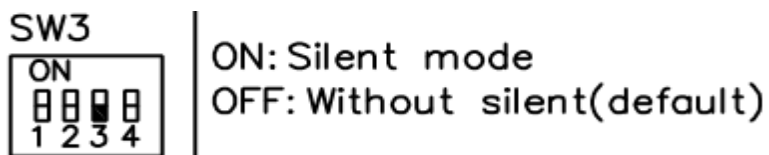

### 1.5 Refrigerant cooling

Resulted in reduce air flow resistance and ensures stability of PCB temperature.



### 1.6 2-stage oil return

1-stage capillary oil return: Normal environment high efficiency and low consumption.

2-stage solenoid valve oil return: Poor environment Guarantee oil return, high efficiency and reliability.

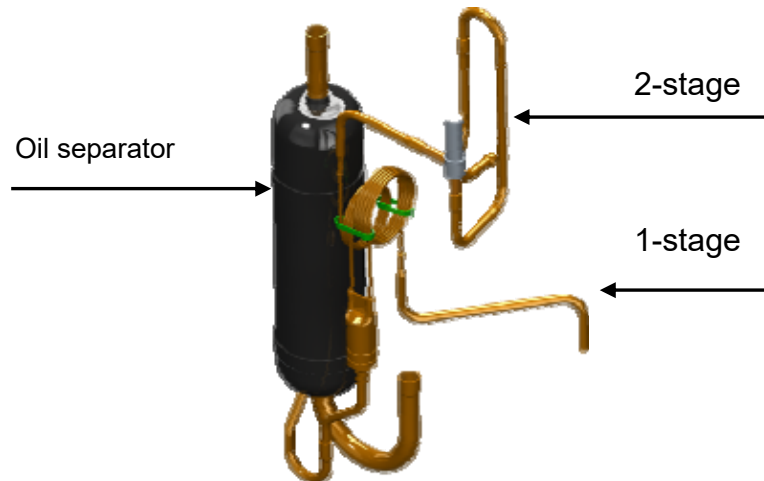

### 1.7 Auxiliary heating belt

Auxiliary heating belt can increase compressor oil temperature in the winter, make sure oil not freeze to protect compressor



### 1.8 Intelligent defrosting

AUX intelligent defrosting technology, extend the heating operation and decrease the frequency of defrosting. Result in stable room temperature, offer comfort life

### 1.9 Diversification of installation



A various of indoor units can be connected together, 2~9 indoor units can be freely combined together in one systems. So Mini VRF is the best choose for some place which had 2 ~ 9 rooms.

### 1.10 Automatic address setting

After install indoor and outdoor unit , Power on the system , can set SW2 -2 to ON , means you had chosen the auto addressing function ,then the system will auto distribute the indoor address instead of manual setting , more convenient for commissioning .

## 2. Product lineup

### 2.1 Outdoor unit

Appearance	Capacity ( cooling/ heating )	Power	Model
	8/9	220V-240V/1-50 &60Hz	ARV-H80/NR1A
	10/12		ARV-H100/NR1A
	12.1/14		ARV-H120/NR1A
	14/16		ARV-H140/NR1A
	15.5/18		ARV-H160/NR1A
	8/9		ARV-H80/NR1
	10/11.5		ARV-H100/NR1
	12.3/13.2		ARV-H120/NR1
	14/16		ARV-H140/NR1
	16/18		ARV-H160/NR1
	12.3/14	380-415V/3N ~ 50&60Hz	ARV-H120/SR1DCS7
	14/16		ARV-H140/SR1DCS7 ARV-H140/SR1DCSA
	16/18		ARV-H160/SR1DCS7 ARV-H160/SR1DCSA
			22.4/24.5
26.0/28.5		ARV-H260/SR1DCS7	
22.4/24.5		380-415V/3N ~ 50HZ	ARV-H220/5R1A
26.0/28.5			ARV-H280/5R1A

**2.2 Indoor unit**

※please refer to indoor units technical manual

**2.3 Nomenclatures**

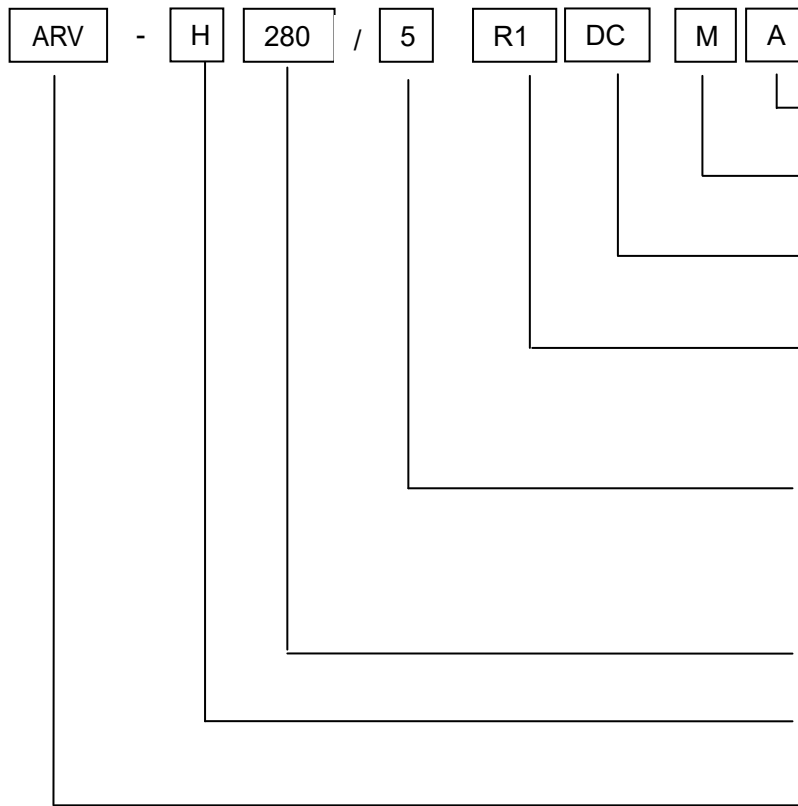

- Design Series Code**
- M:** Modular outdoor unit  
Non-Modular one omitted
- DC:** Direct current inverter  
Alternating current inverter omitted
- Refrigerant type:**
- R1:** R410A    R22 Omitted
- Power supply:**
- 2:** 220-240V~, 1Ph, 60Hz
- 4:** 220-240V~, 1Ph, 50Hz
- 5:** 380-415V~, 3Ph, 50Hz
- 6:** 380-415V~, 3Ph, 60Hz
- 9:** 208-230V~, 3Ph, 60Hz
- N:** 220-240V~, 1Ph, 50/60Hz
- S:** 380-415V~, 3Ph, 50/60Hz
- Cooling capacity(×100W)**
- H:** Cooling & Heating
- C:** Cooling only
- AUX Refrigerant Variable**

## Part2 Outdoor Engineering Data

### 1. Specifications

※ Please refer to EXCEL

### 2. Capacity table

ARV-H80/NR1A、ARV-H100/NR1A、ARV-H120/NR1A、ARV-H140/NR1A、ARV-H160/NR1A

ARV-H80/NR1、ARV-H100/NR1、ARV-H120/NR1、ARV-H140/NR1、ARV-H160/NR1、

ARV-H120/SR1DCS7、ARV-H140/SR1DCS7、ARV-H160/SR1DCS7

ARV-H140/SR1DCSA、ARV-H160/SR1DCSA

ARV-H224/SR1DCS7、ARV-H260/SR1DCS7

ARV-H220/5R1A、ARV-H280/5R1A

Cooling and Heating capacity table see another handbook in detail

The specifications are subject to change without prior notice. Final specifications please refer to technical specification provided by sales representative

### 3. Connection ratio

Connection ratio is 50~130%

$\frac{\text{Total capacity of indoor units (one system)}}{\text{Capacity of outdoor units(one system)}} = \text{Connection ration}$
--

### 4. Long Piping Length

※ Please refer to Installation & Operation Manual

### 5. Sound level

1. The operating condition are assumed to be standard (JIS Condition).
2. These operating values were obtained in a dead room (conversion values).  
Sound level will vary depending on a range of factors such as the construction (acoustic absorption coefficient) of the particular room in which the equipment installed.
3. The result is the biggest one of four testing device.
4. Test height (Unit height +1)/2m, horizontal distance: 1m.



### Vertical View

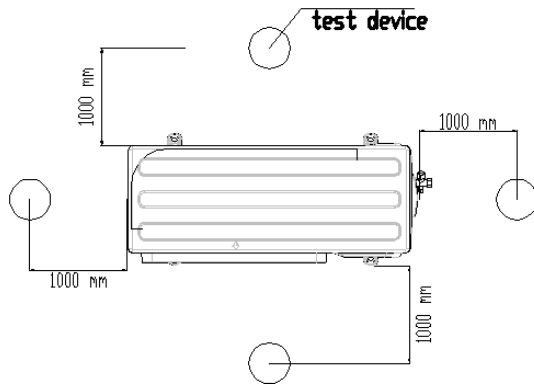

### side view

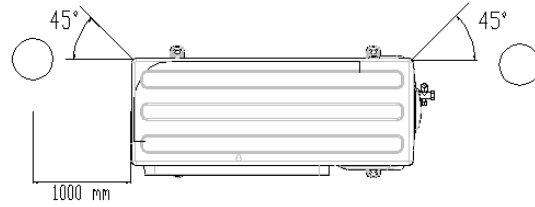

Model	Sound (dB)
<b>ARV-H80/NR1A</b>	<b>54</b>
<b>ARV-H100/NR1A</b>	<b>54</b>
<b>ARV-H120/NR1A</b>	<b>56</b>
<b>ARV-H140/NR1A</b>	<b>56</b>
<b>ARV-H160/NR1A</b>	<b>56</b>
ARV-H80/NR1	56
ARV-H100/NR1	56
ARV-H120/NR1	57
ARV-H140/NR1	57
ARV-H160/NR1	57
ARV-H120/SR1DCS7	56
ARV-H140/SR1DCS7	57
ARV-H140/SR1DCSA	57
ARV-H160/SR1DCS7	57
ARV-H160/SR1DCSA	57
ARV-H224/SR1DCS7	62
ARV-H260/SR1DCS7	62
ARV-H220/5R1A	60
ARV-H280/5R1A	60

# Part3 Refrigerant Circuit

## 1.Piping diagrams

### 1.1 Cooling Mode

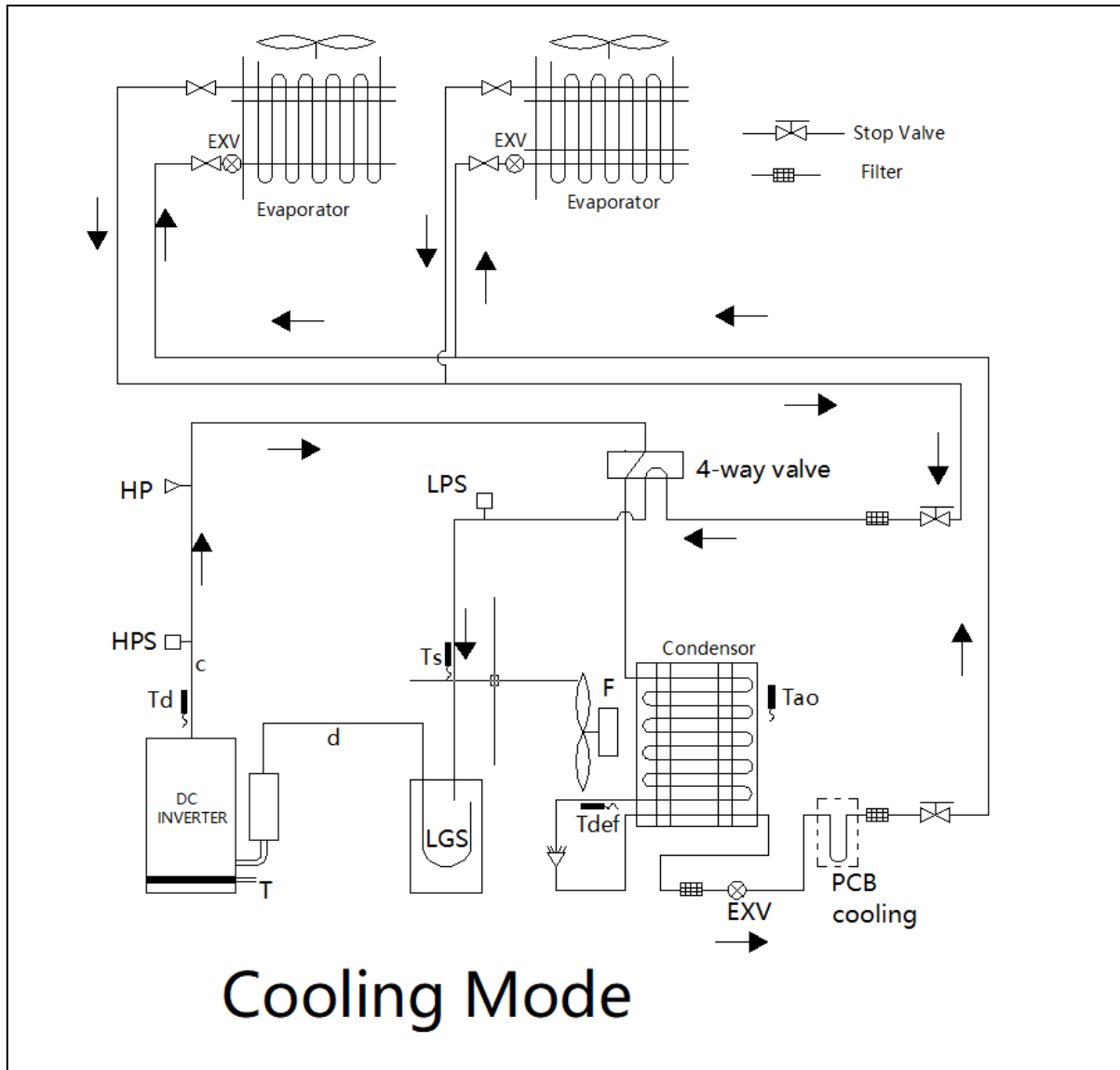

Model
ARV-H80/NR1A
ARV-H100/NR1A
ARV-H120/NR1A

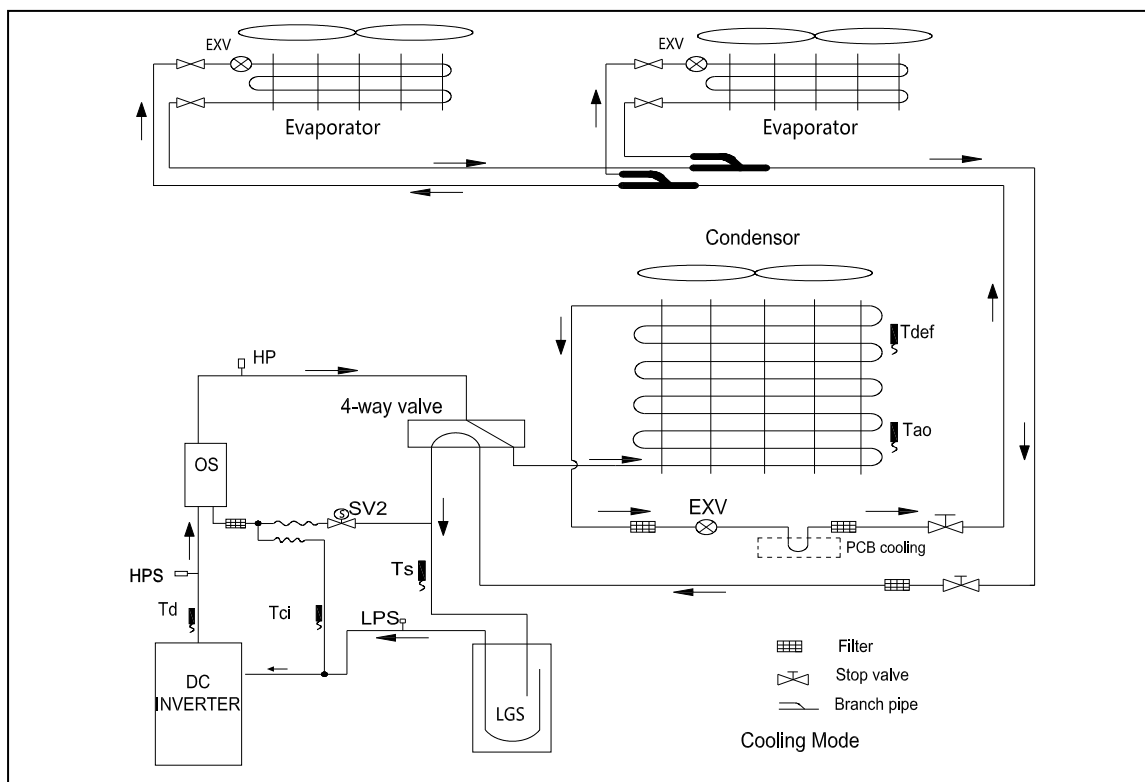

Model	Model
ARV-H140/NR1A	ARV-H140/SR1DCS7
ARV-H160/NR1A	ARV-H140/SR1DCSA
ARV-H80/NR1	ARV-H160/SR1DCS7
ARV-H100/NR1	ARV-H160/SR1DCSA
ARV-H120/NR1	ARV-H224/SR1DCS7
ARV-H140/NR1	ARV-H260/SR1DCS7
ARV-H160/NR1	ARV-H220/5R1A
ARV-H120/SR1DCS7	ARV-H280/5R1A

Comp.	Component description	Comp.	Component description
Td	Exhaust temperature sensor	LGS	Gas-liquid separator
HPS	High pressure switch	Ts	Suction temperature sensor
OS	Oil separator	EXV	Electronic expansion valve
HP	High pressure sensor	Tdef	Defrost temperature sensor
SV2	Oil return valve	Tao	Outside environment temperature sensor
Tci	Oil temperature sensor	LPS	Low pressure switch

1.2 Heating Mode

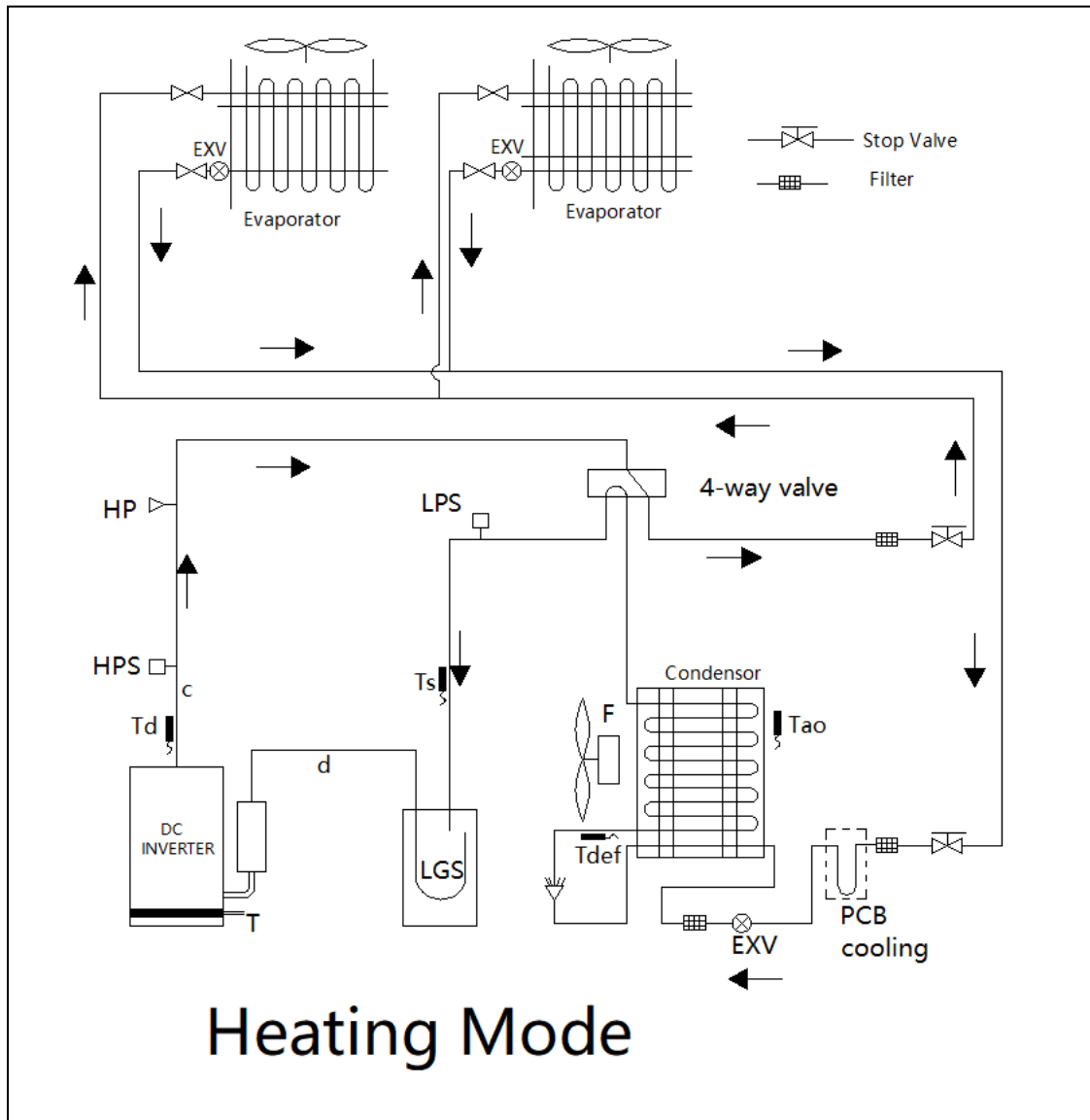

Model
ARV-H80/NR1A
ARV-H100/NR1A
ARV-H120/NR1A

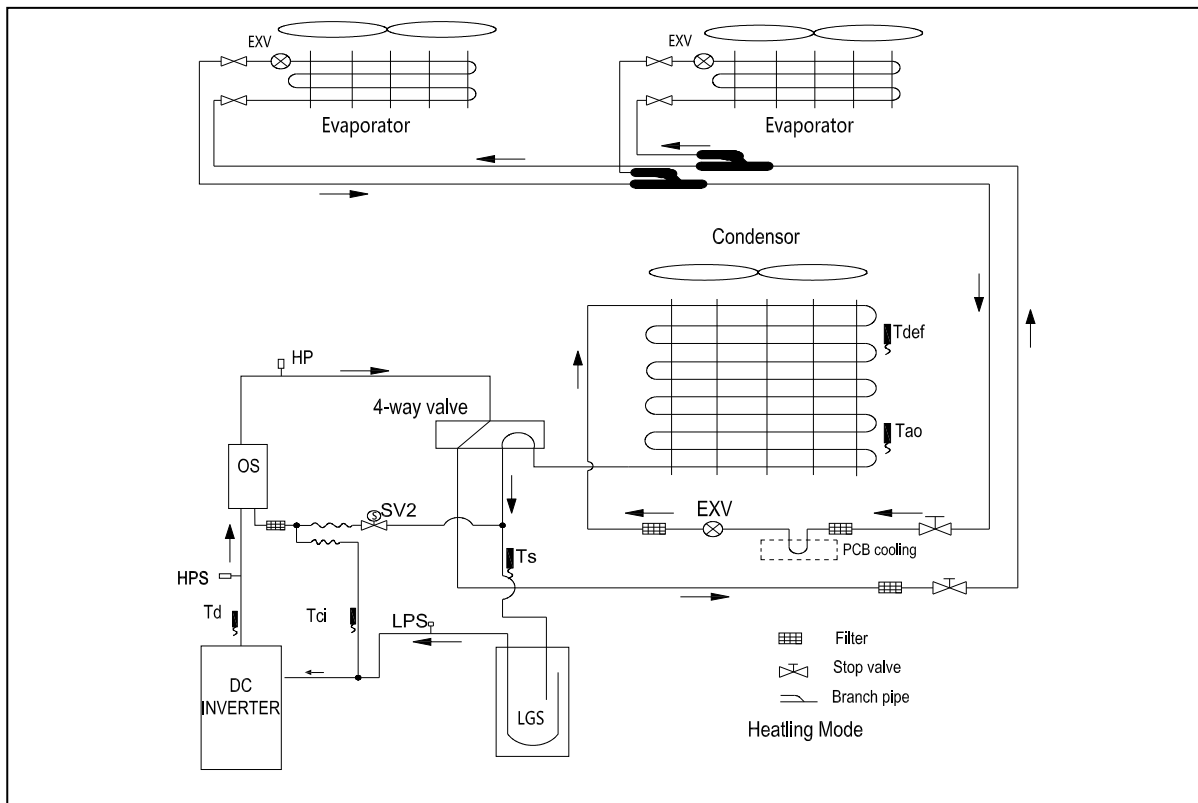

<b>Model</b>	<b>Model</b>
<b>ARV-H140/NR1A</b>	<b>ARV-H140/SR1DCS7</b>
<b>ARV-H160/NR1A</b>	<b>ARV-H140/SR1DCSA</b>
<b>ARV-H80/NR1</b>	<b>ARV-H160/SR1DCS7</b>
<b>ARV-H100/NR1</b>	<b>ARV-H160/SR1DCSA</b>
<b>ARV-H120/NR1</b>	<b>ARV-H224/SR1DCS7</b>
<b>ARV-H140/NR1</b>	<b>ARV-H260/SR1DCS7</b>
<b>ARV-H160/NR1</b>	<b>ARV-H220/5R1A</b>
<b>ARV-H120/SR1DCS7</b>	<b>ARV-H280/5R1A</b>

Comp.	Description	Comp.	Description
Td	Exhaust temperature sensor	LPS	Low pressure switch
HPS	High pressure switch	LGS	Gas-liquid separator
OS	Oil separator	Ts	Suction temperature sensor
HP	High pressure sensor	EXV	Electronic expansion valve
SV2	Oil return valve	Tdef	Defrost temperature sensor
Tci	Oil temperature sensor	Tao	Outside environment temperature sensor

## Part4 Installation

Please refer to the installation & operation manual

## Part5 Commissioning

### 1. Preparatory work

#### 1.1 Inspection and confirmation before commissioning

- ✧ Confirm that refrigeration piping and communication wire of indoor and outdoor units have been connected to the same refrigeration system in order avoid unnecessary malfunctions.
- ✧ Confirm power voltage is within  $\pm 10\%$  rated voltage.
- ✧ Confirm that the power wire and control wire are correctly connected, the power phase sequence of outdoor unit is corrected, and the outdoor unit can detect each indoor unit.
- ✧ Confirm wired controller is properly connected.
- ✧ Confirm all units have passed nitrogen pressure-keeping test for 24 hours.
- ✧ Confirm the system has been carried out vacuum drying and charged with refrigeration as required.

#### 1.2 Preparation before start up

- ✧ Turn on power switches of outdoor unit in advance, and keep connected for a minimum of 8 hours to ensure refrigerant oil is sufficiently heated.
- ✧ Turn on all valves. If valves are not fully open unit may be damaged.
- ✧ All dial switches of indoor / outdoor units have been set according to the technical requirements.

#### 1.3 Commissioning

Inspection list of trial run:

- ✧ Confirm the fan impeller is rotating according to its intended route and turns smoothly.
- ✧ Check for abnormal noise during operation of refrigerant system and compressor.
- ✧ Confirm drainage is smooth and its lift pump is operational.
- ✧ Confirm operating current is within the allowed range.

✧ Confirm each operating parameter is within the range permitted by the equipment.

**Note:** Separately test cooling mode and heating mode to judge the stability and reliability of the system.

#### 1.4 Refrigerant leakage caution

This air conditioner adopts R410A as refrigerant, which is safe and noncombustible.

R410A critical thickness: 0.3kg/m<sup>3</sup> (Critical thickness: the max thickness of Freon without any harm to person).

Calculate the critical thickness through following steps, and take necessary actions.

- 1) Calculate the refrigerant charge volume A, A= factory charge volume + additional charge volume
- 2) Calculate the indoor area volume (B) (as the minimum volume)
- 3) Calculate the refrigerant thickness,  $A/B \leq$  critical thickness 0.3kg/m<sup>3</sup>.

**Note:**

In winter, supply power 6 hours in advance for initial operation so that crankshaft case can be preheated in advance.

In winter, after main power supply is interrupted for 6 hours, conduct trial operation again only after 2.5 hours of power-on.

## 2.Electrical schematic diagram

### 2.1 ARV-H80/NR1A、 ARV-H100/NR1A 、 ARV-H120/NR1A 、 ARV-H140/NR1A 、 ARV-H160/NR1A

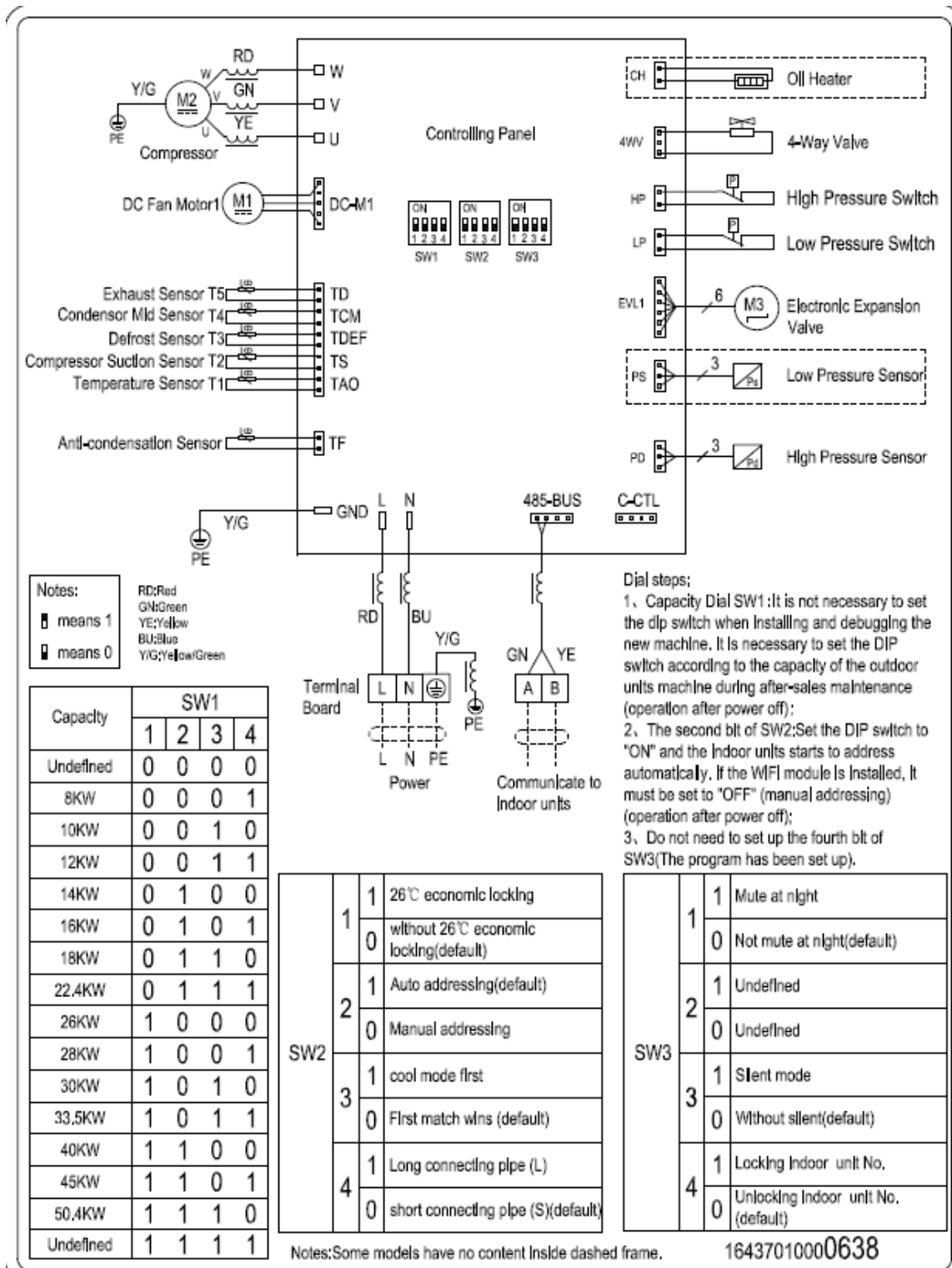



2.2 ARV-H80/NR1、 ARV-H100/NR1 、 ARV-H120/NR1 、 ARV-H140/NR1A 、  
ARV-H160/NR1

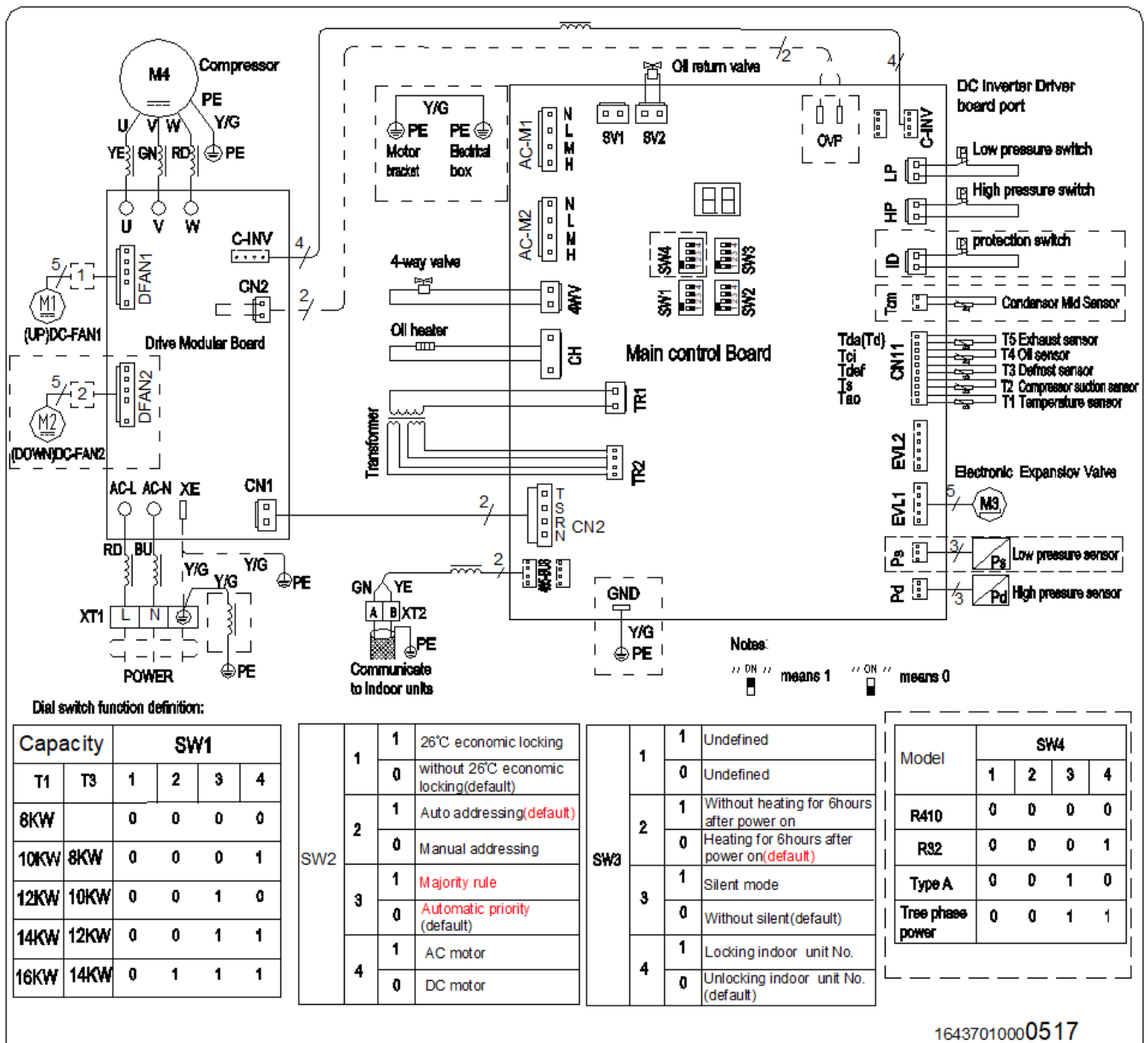

16437010000517

2.3 ARV-H120/SR1DCS7、ARV-H140/SR1DCS7、ARV-H140/SR1DCSA、  
ARV-H160/SR1DCS7、ARV-H160/SR1DCSA

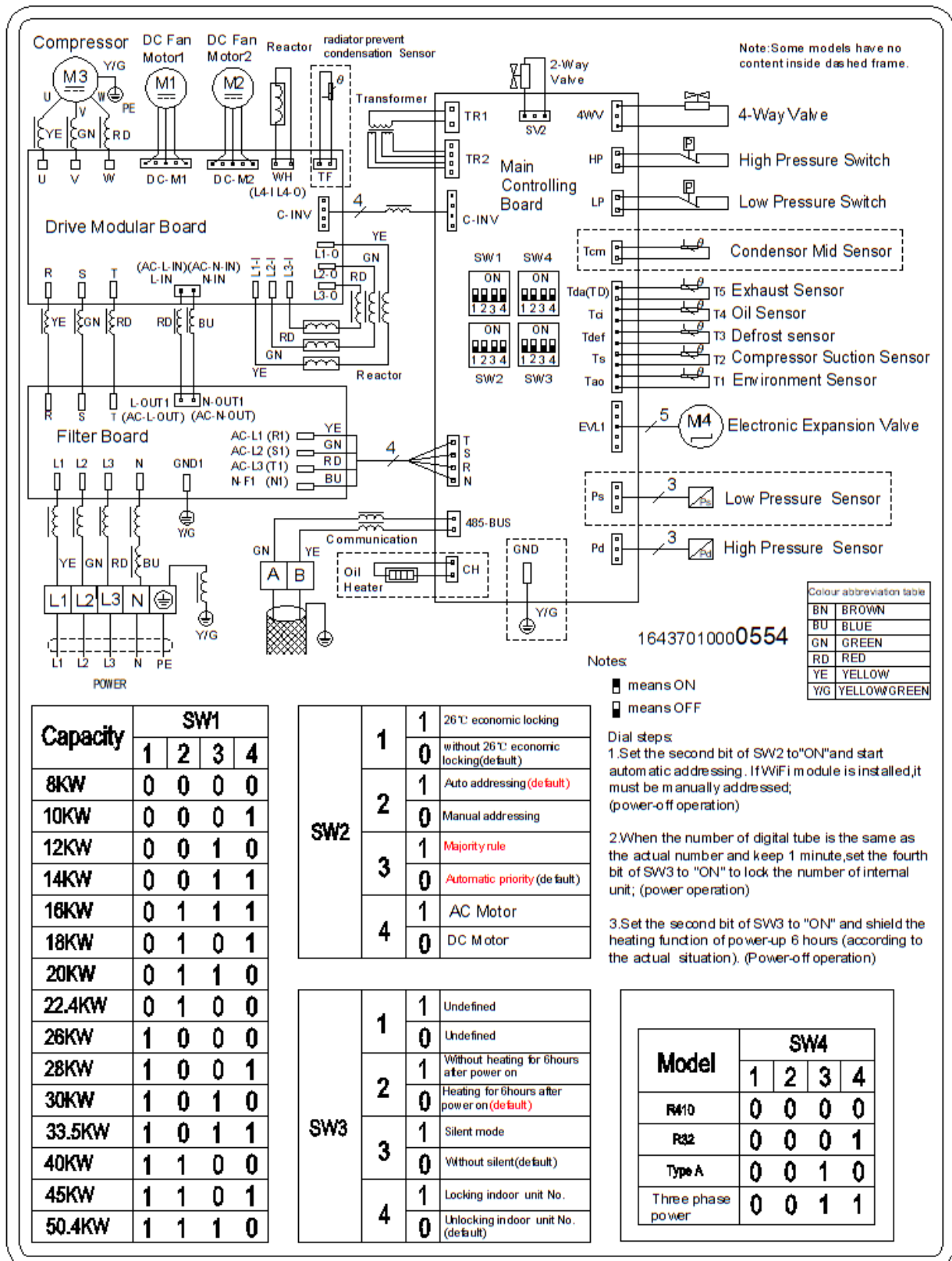

2.4 ARV-H220/SR1DCS7、ARV-H260/SR1DCS7

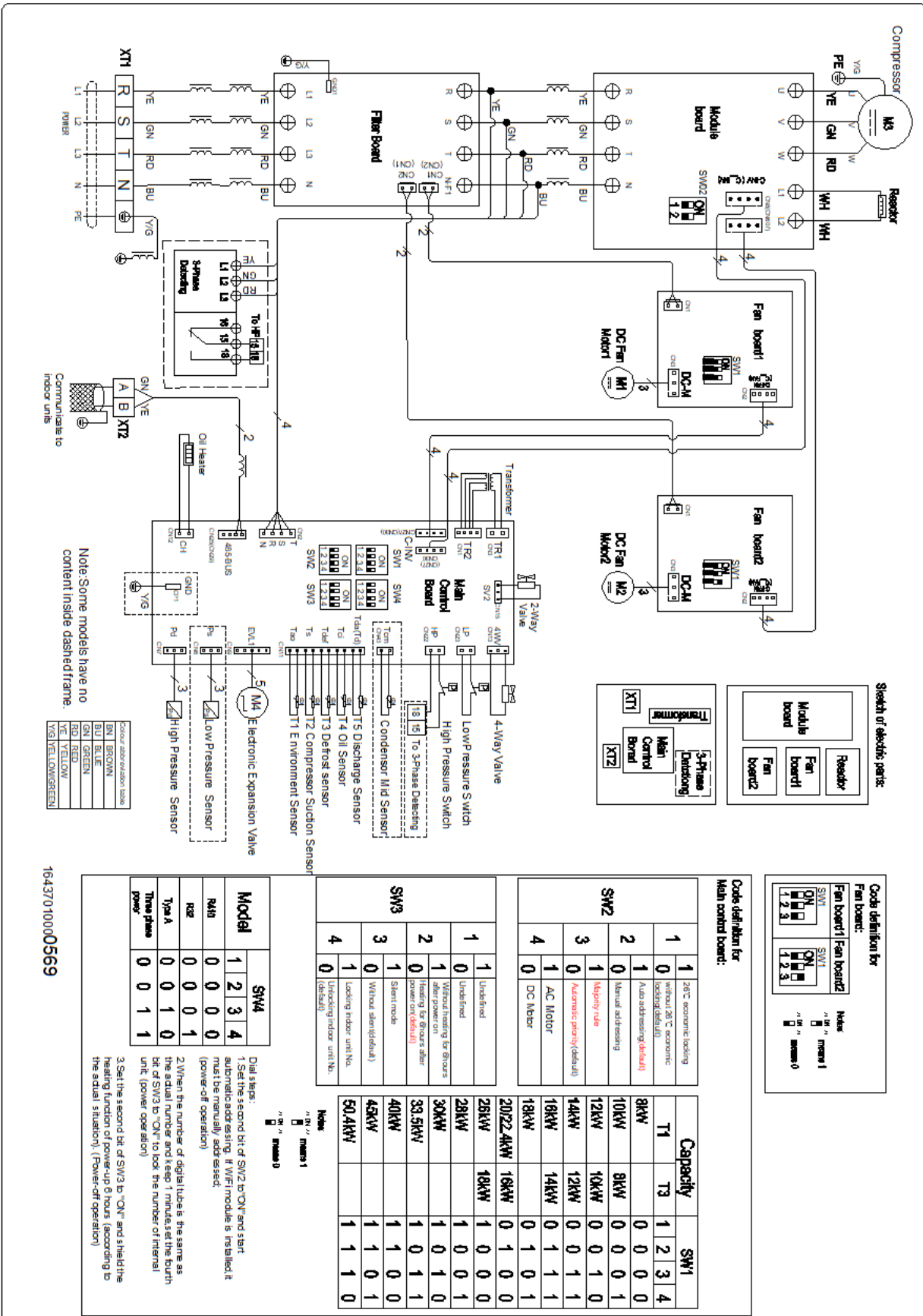

2.5 ARV-H220/5R1A、ARV-H280/5R1A

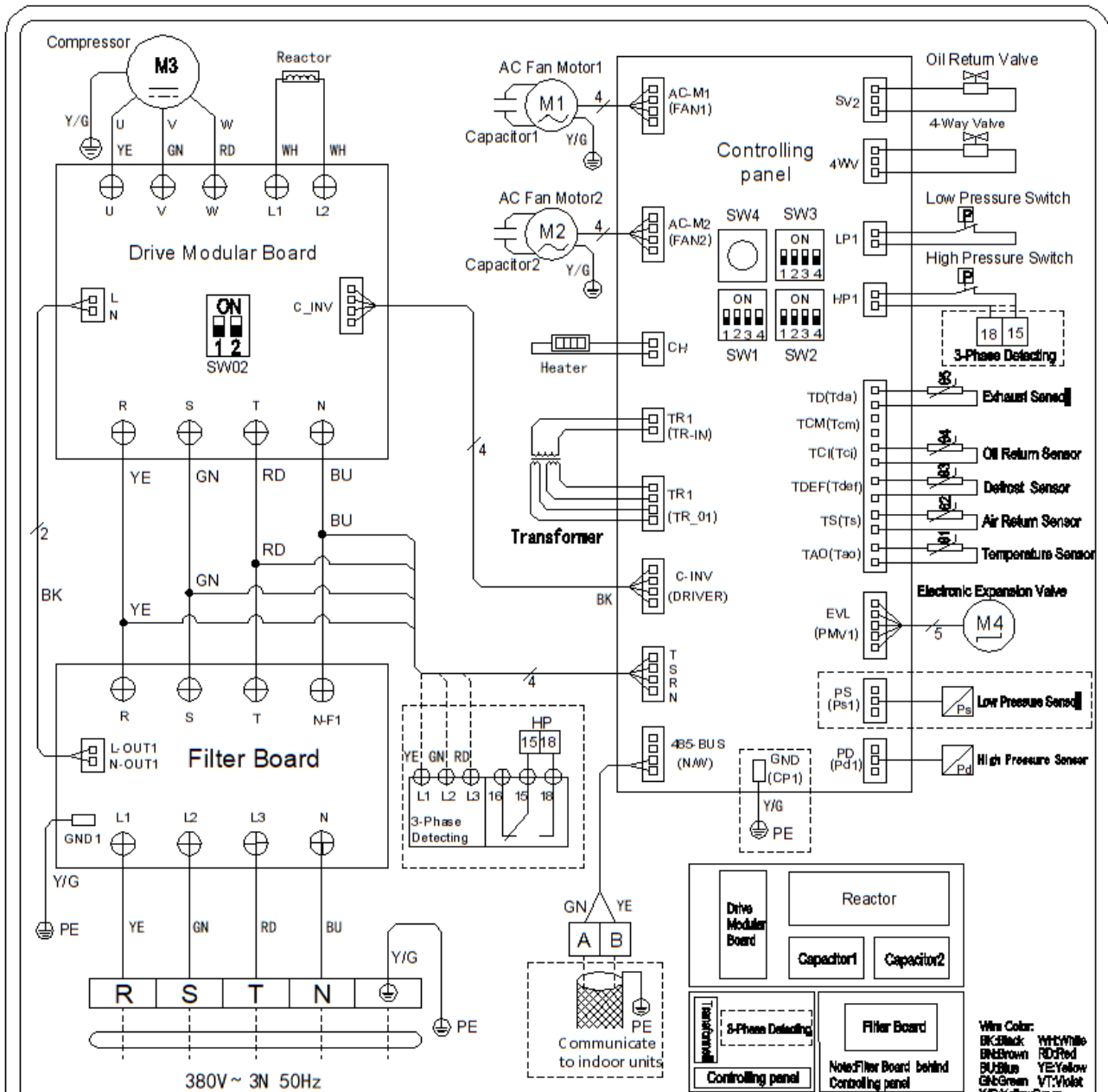

Layout of the reference

SW1 function definition: the unit capacity setting				SW2 function definition: function selection				SW3 function definition: function selection				Note: ON : means 1      OFF : means 0 Dial steps: 1: Set the second bit of SW2 to "ON" and alert automatic addressing. If WIFI module is installed, it must be manually addressed; (power-off operation) 2: When the number of digital tube is the same as the actual number and keep 1 minute, set the fourth bit of SW3 to "ON" to lock the number of internal unit; (power operation) 3: Set the second bit of SW3 to "ON" and shield the heating function of power-up 6 hours (according to the actual situation). (Power-off operation)			
Capacity	1	2	3	4	Capacity	1	2	3	4	Capacity	1		2	3	4
8KW	0	0	0	0	18KW	0	1	0	1	30KW	1	0	1	0	
10KW	0	0	0	1	20KW	0	1	1	0	33.5KW	1	0	1	1	
12KW	0	0	1	0	22.4KW	0	1	0	0	40KW	1	1	0	0	
14KW	0	0	1	1	26KW	1	0	0	0	45KW	1	1	0	1	
16KW	0	1	1	1	28KW	1	0	0	1	50.4KW	1	1	1	0	
1: 26°C economic locking 2: without 26°C economic locking (default)				1: Auto addressing 0: Manual addressing (default)				1: Single phase unit 0: Three phase unit (default)							
1: cool mode first 0: F first match wins (default)				1: AC Motor 2: DC Motor				1: Without heating for 6 hours after power on 0: Heating for 6 hours after power on (default)							
								1: Silent mode 0: Without silent (default)							
								1: Locking indoor unit No. 0: Unlocking indoor unit No. (default)							

Note: Some models have no content inside dashed frame.

16437010000600

### 3.1 Control PCB port

**3.1 ARV-H80/NR1A、 ARV-H100/NR1A 、 ARV-H120/NR1A 、 ARV-H140/NR1A 、 ARV-H160/NR1A**

- Integrated PCB

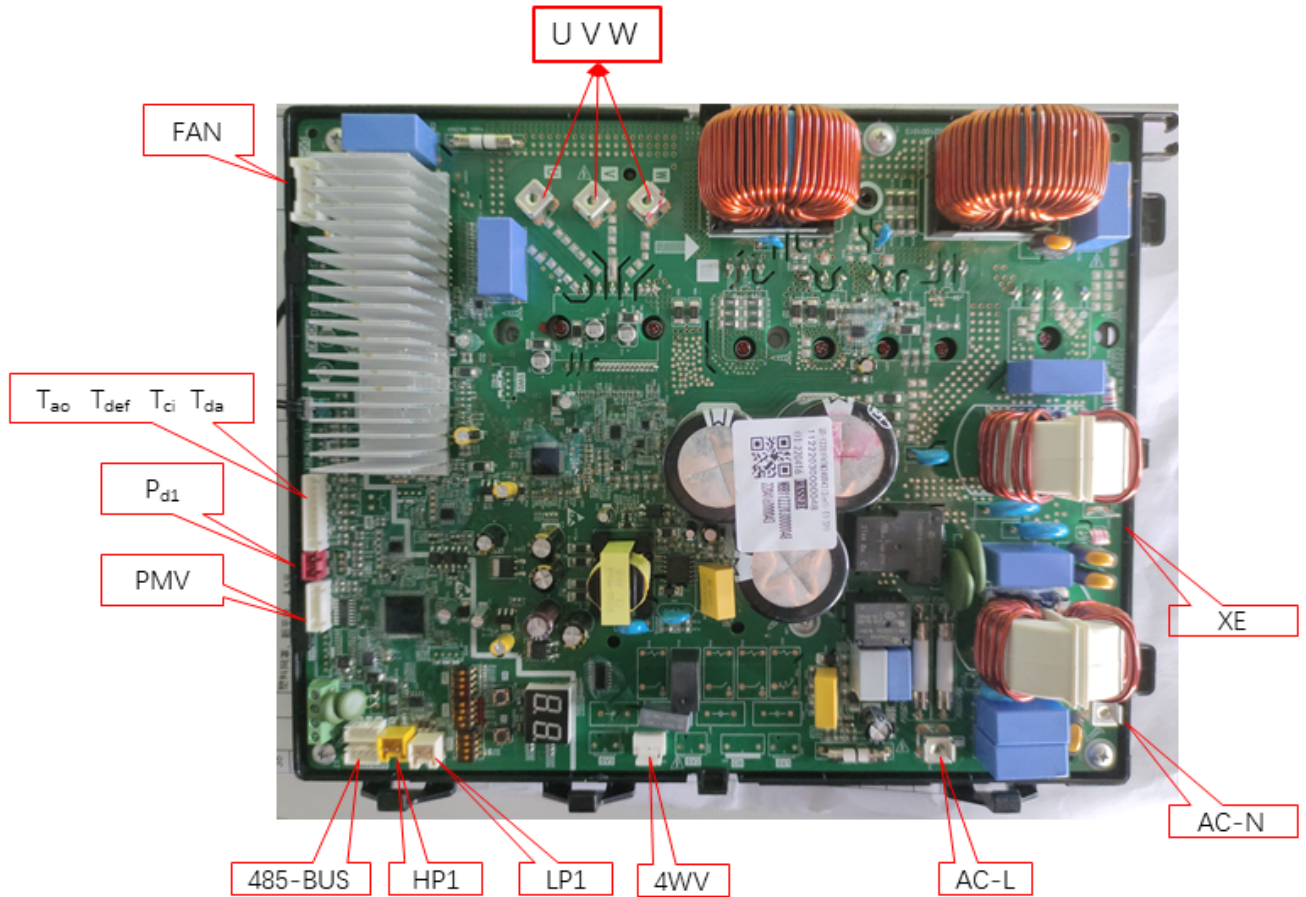

U V W	Power	Tda	Environment temperature Sensor
FAN	DC FAN	Tao	Exhaust temperature sensor
4WV	4-way valve	PWV	EXV
LP1	Low pressure switch	Pd1	High pressure sensor
HP1	High pressure switch	AC-L	Power (L)
485-BUS	Communication	AC-N	Power (N)
Tao	Exhaust temperature sensor	XE	Ground wire
Tdef	Defrost Sensor		
Tci	Compressor suction sensor		

Model	Code	Name	Remark
ARV-H080/NR1A	11222030000048	散热器模块组件 QD-12201FKTM240D43 (3in1)-E1(SY)	1、 Same appearance 2、 Same connect port Different program
ARV-H100/NR1A			
ARV-H120/NR1A	11222030000047	散热器模块组件 QD-12211FQXAS-D32z X090B-E1(SY)	
ARV-H140/NR1A	11222030000046	散热器模块组件	
ARV-H160/NR1A		QD-1232(5KD420ZAA21 ) (3in1)-E1(SY)	

3.2 ARV-H80/NR1、 ARV-H100/NR1、 ARV-H120/NR1、 ARV-H140/NR1、 ARV-H160/NR1

- Main PCB

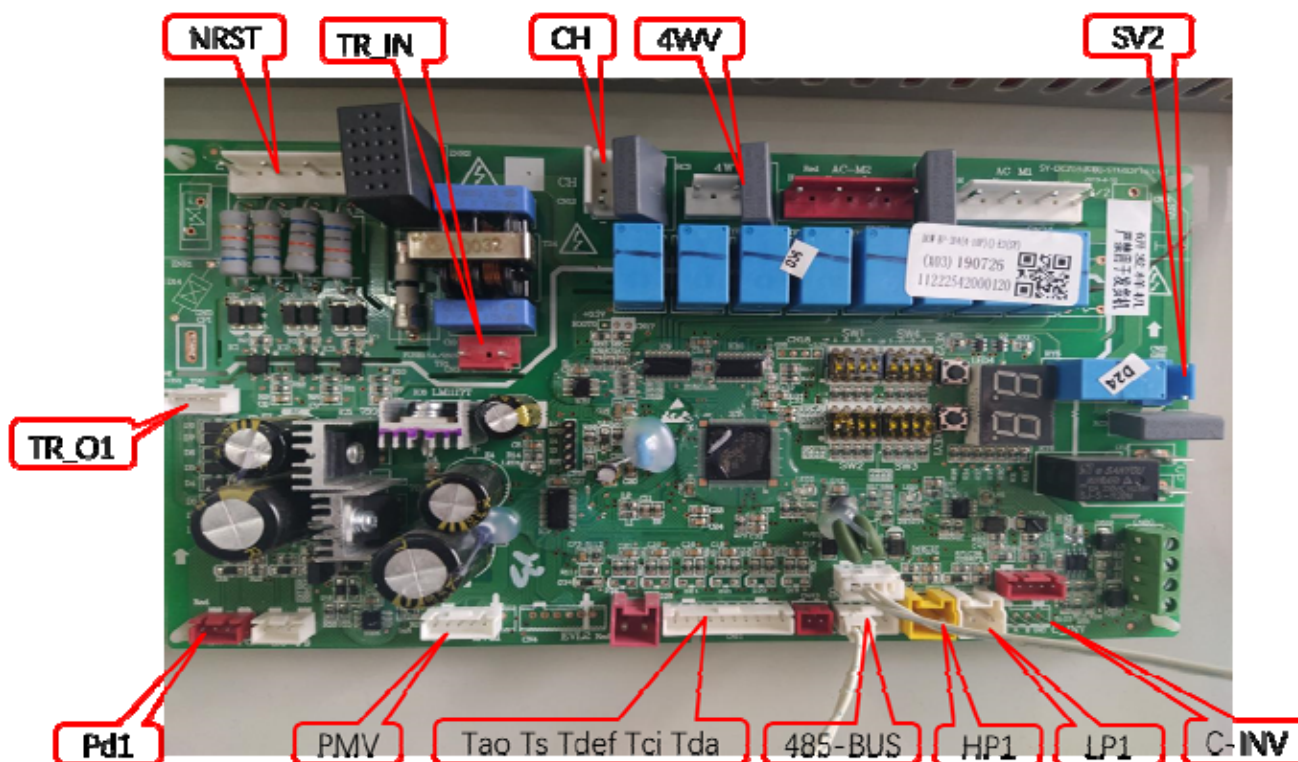

N R S T	Power input	485-BUS	Communication
TR_IN	Transform input	Tao	Exhaust temperature sensor

TR_O1	Transform output	Ts	Oil temperature sensor
CH	Compressor preheating/ Oil heater	Tdef	Defrost Sensor
4WV	4-way valve	Tci	Compressor suction sensor
SV2	Oil return valve	Tda	Environment temperature Sensor
C-INV	DC Inverter driver board port	PWV1	EXV
LP1	Low pressure switch	Pd1	High pressure sensor
HP1	High pressure switch		

Model	Code	Name	Remark
ARV-H80/NR1	11222542000128	CJ 控制板 DLW-BP-3F4(3-10P)(小多 联)-E4(SY)	1、 Same appearance  2、 Same connect port Different program
ARV-H100/NR1			
ARV-H120/NR1			
ARV-H140/NR1			
ARV-H160/NR1			

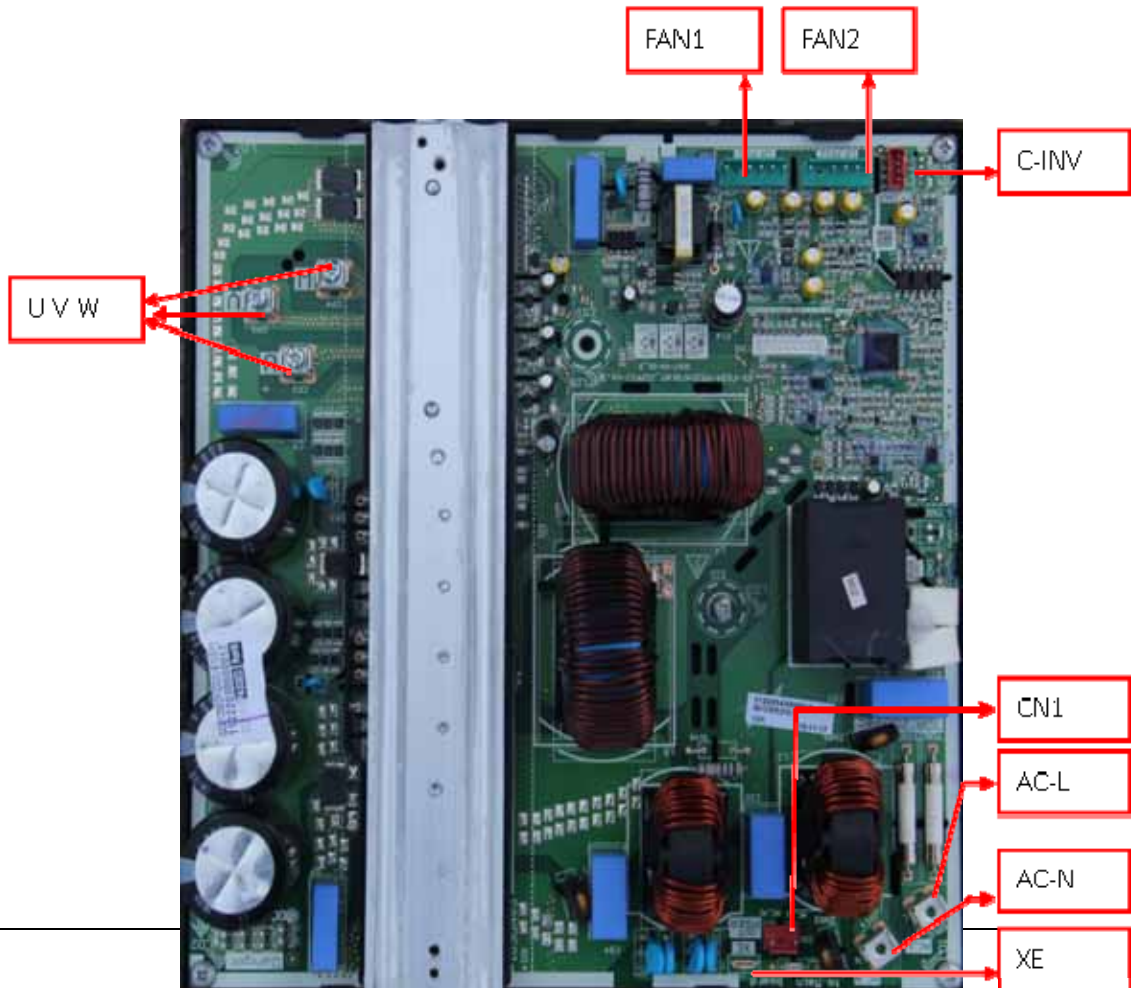

<b>U V W</b>	Power
<b>FAN 1</b>	DC FAN 1(UP)
<b>FAN 2</b>	DC FAN 2(DOWN)
<b>C-INV</b>	DC Inverter driver board port
<b>CN1</b>	Power (L N )
<b>AC-L</b>	Power (L )
<b>AC-N</b>	Power (N )
<b>XE</b>	Ground wire

### Compressor & Fan drive modular

Model	Code	Name	Remark
ARV-H80/NR1	11222030000020	散热器模块组件	1、 Same appearance 2、 Same connect port Different program
ARV-H100/NR1		QD-12201F(DA250)	
ARV-H120/NR1	11222030000017	散热器模块组件	
ARV-H140/NR1		QD-12302F(D32)	
ARV-H160/NR1	11222030000016	散热器模块组件	
		QD-12302F(F428)	

### 3.3 ARV- H120/SR1DCS7、 ARV- H140/SR1DCS7、 ARV- H140/SR1DCSA、 ARV- H160/SR1DCS7、 ARV- H160/SR1DCSA

- Main PCB



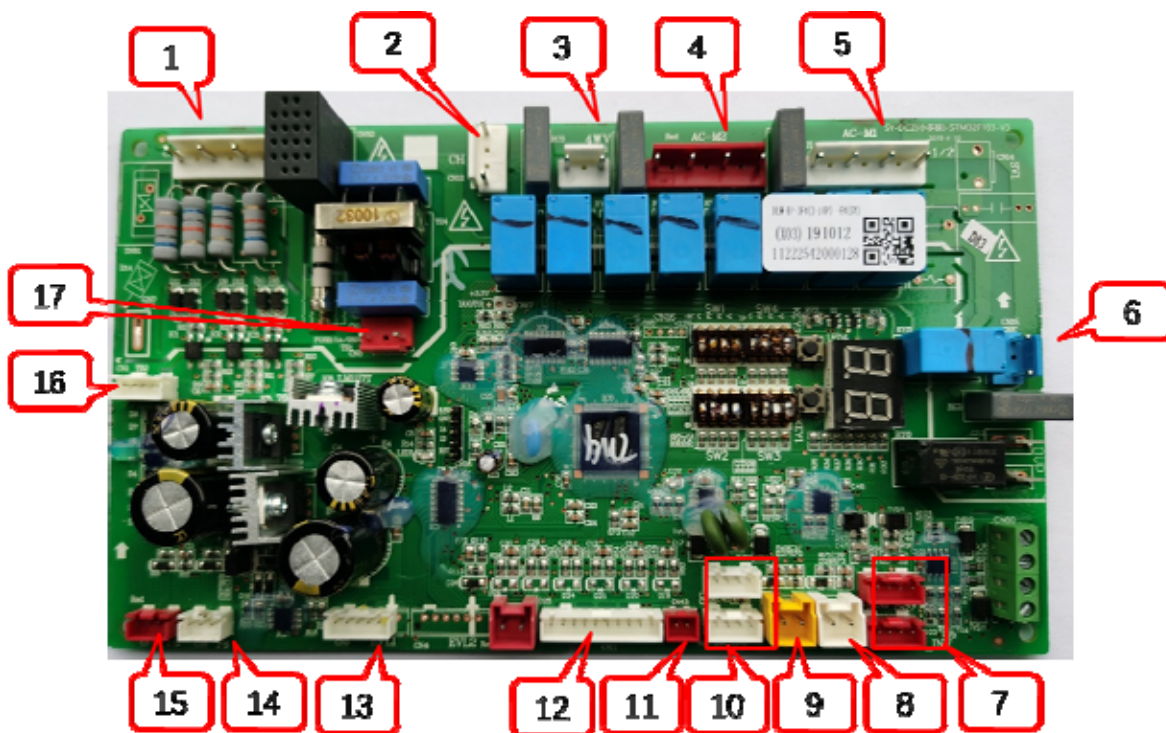

1	N R S T Power input from filter board	10	485-BUS 485 signal
2	CH electrical heater	11	CN 43 condenser mid sensor
3	4WV To four way valve	12	CN11 sensor group
4	AC-M2 to AC fan motor 1	13	EVL1 to EXV
5	AC-M1 to AC fan motor 2	14	CN6 to low pressure sensor
6	SV2 Solenoid valve	15	CN7 to high pressure sensor
7	CN27 To compressor drive board CN30 To fan drive board	16	CN1 to transformer
8	LP low pressure switch	17	CN3 to transformer
9	HP high pressure switch		

Model	Code	Name	Remark
ARV-H120/SR1DCS7	11222542000128	CJ 控制板 DLW-BP-3F4(3-10P)(小 多联)-E4(SY)	1、 Same appearance
ARV-H140/SR1DCS7			
ARV-H160/SR1DCS7			2、 Same connect port Different program
ARV-H140/SR1DCSA	11222542000134	CJ 控制板 DLW-BP-3F4(3-10P)(小	

ARV-H160/SR1DCSA		多联)(以色列)-E4(SY)	
------------------	--	-----------------	--

- Filter board 1122254800003 CJ 滤波板 LB-4312-1(SY)

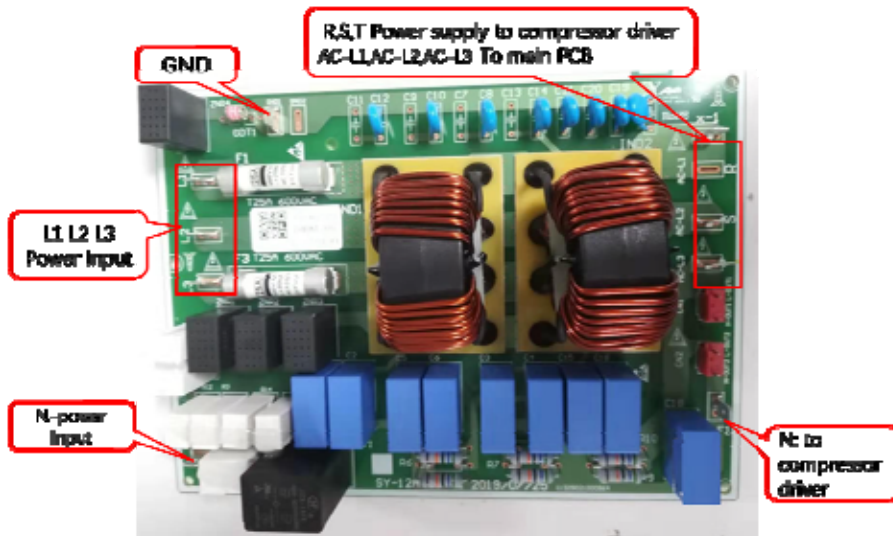

- Compressor & fan motor drive modular

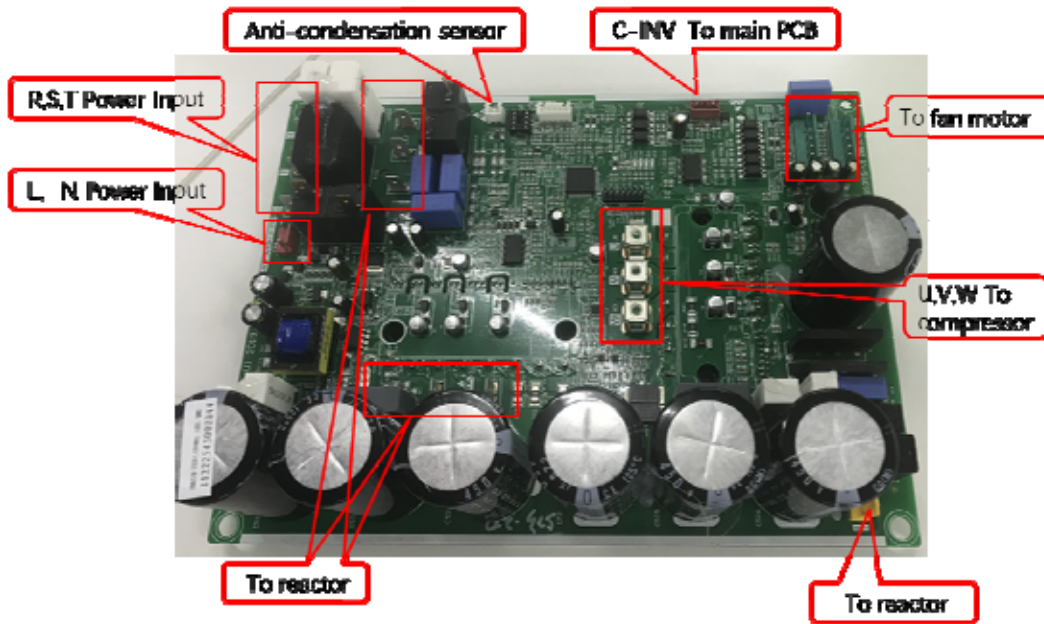

Model	Code	Name	Remark
ARV-H120/SR1DCS7	11222543000047	CJ 模块板 QD-33322F(KTF310D)三相 小多联 12KW-1(SY)	1、 Same appearance 2、 Same connect port Different program
ARV-H140/SR1DCS7	11222543000044	CJ 模块板 QD-33322F(美芝 KTF400D) 三相小多联/以色列-1(SY)	
ARV-H160/SR1DCS7			
ARV-H140/SR1DCSA			
ARV-H160/SR1DCSA			

### 3.4 ARV- H220/SR1DCS7、 ARV- H260/SR1DCS7

- **Main PCB** 11222542000128 CJ 控制板 DLW-BP-3F4(3-10P)(小多联)-E4(SY)

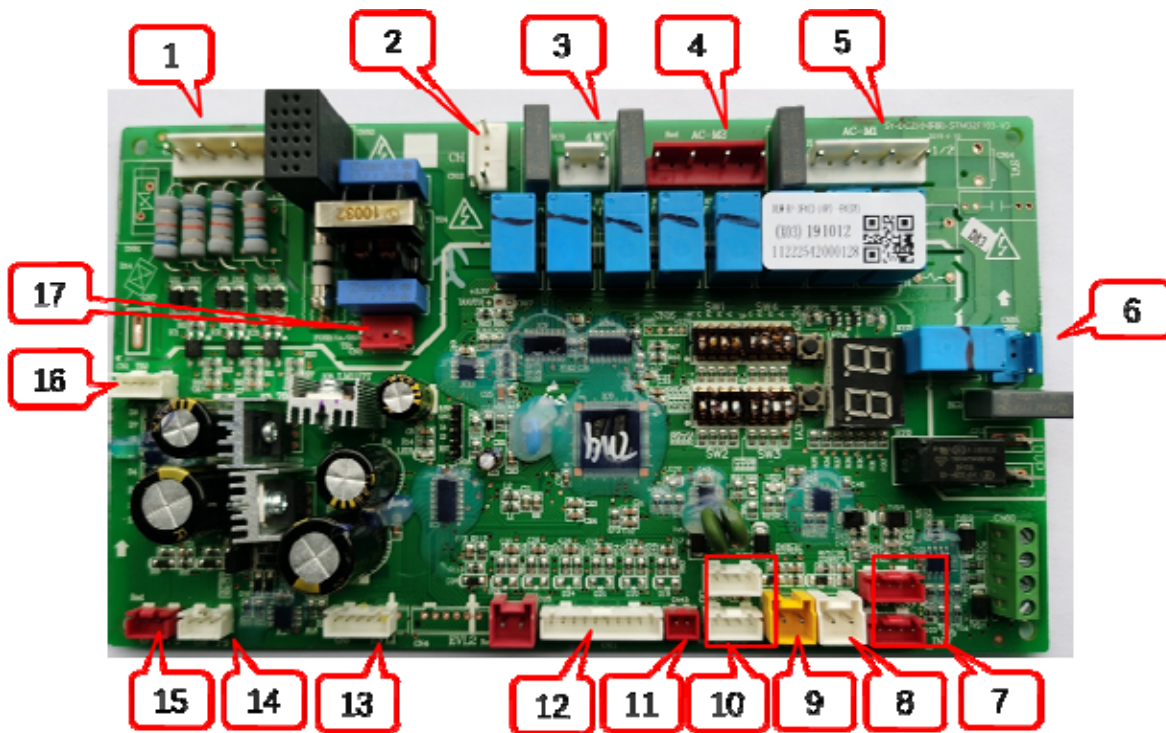

1	N R S T Power input from filter board	10	485-BUS 485 signal
2	CH electrical heater	11	CN 43 condenser mid sensor
3	4WV To four way valve	12	CN11 sensor group
4	AC-M2 to AC fan motor 1	13	EVL1 to EXV
5	AC-M1 to AC fan motor 2	14	CN6 to low pressure sensor
6	SV2 Solenoid valve	15	CN7 to high pressure sensor
7	CN27 To compressor drive board CN30 To fan drive board	16	CN1 to transformer
8	LP low pressure switch	17	CN3 to transformer
9	HP high pressure switch		

- Compressor drive modular 11222030000033 散热器模块组件 QD-3330(三菱 LNB65FAEMC)  
改压机-C2(SY)

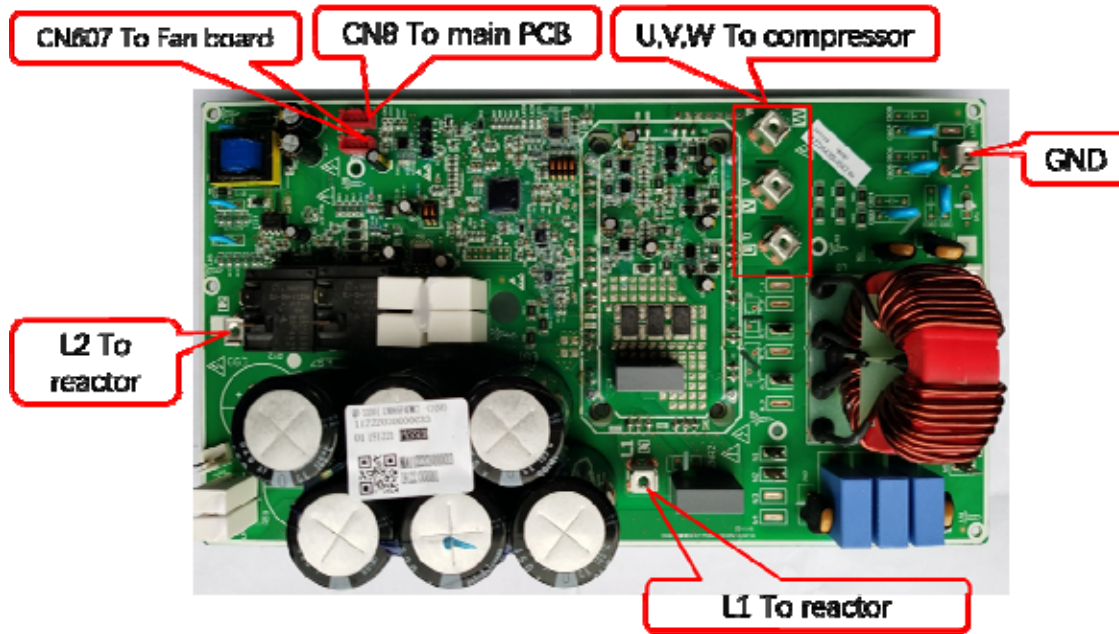

- Fan drive modular 11222543000042 CJ 模块板 QD-12121F200W 风机驱动-2(SY)

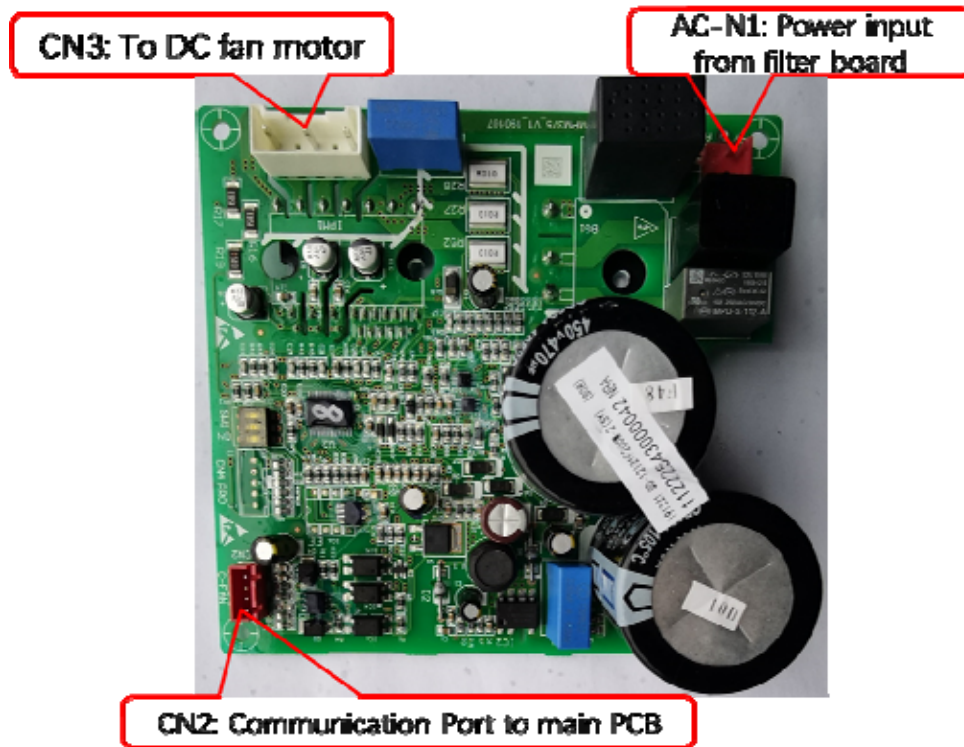

- Filter board 11222548000005 CJ 滤波板 LB-4318-1(SY)CJ

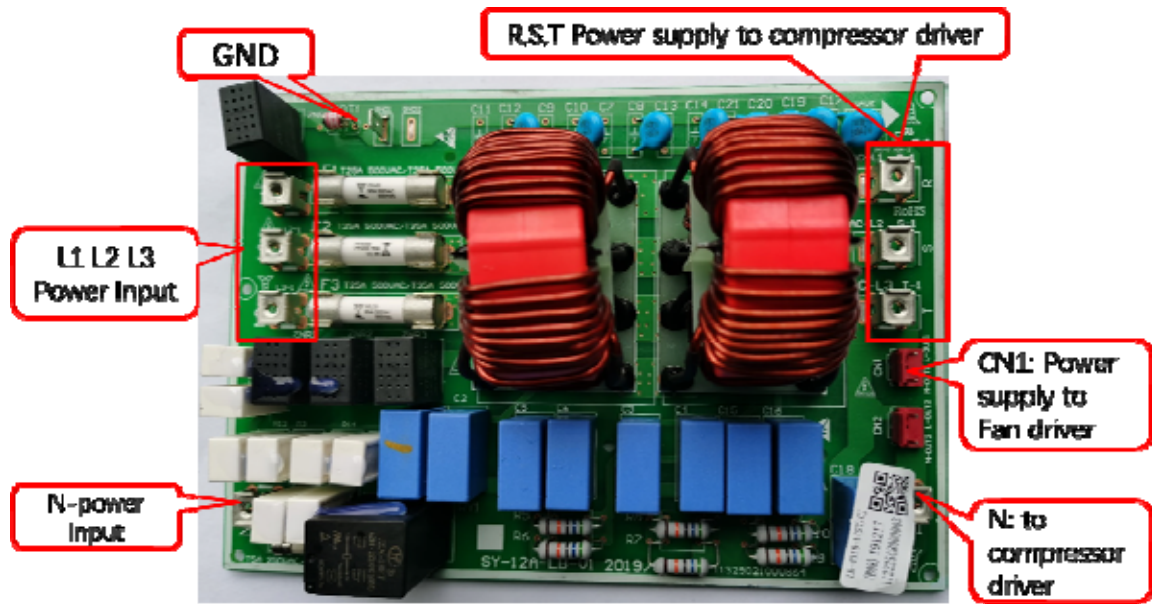

### 3.5 ARV-H220/5R1A、 ARV-H280/5R1A

Master control PCB 1122254200004 控制板 CJ-SW(10PCCF)-SYEDCZ-1

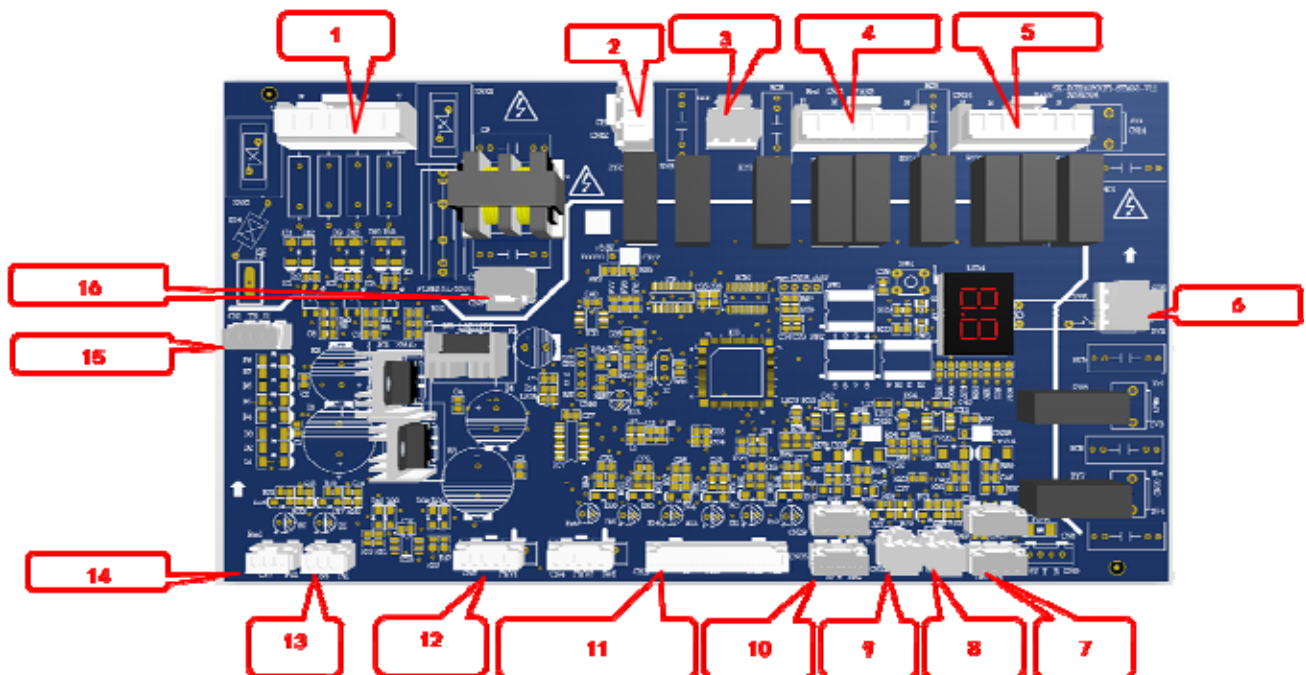

1. Power Input N R S T
2. Oil temperature tropical CH
3. Four-way valve 4WV
4. AC fan FAN2
5. AC fan FAN1
6. Oil return valve SV2
7. Inter-board communication DRIVER
8. Low voltage switch LP1

- 9. High voltage switch LP2
- 10. 485 communication N/W
- 11. Temperature transducer Tao Ts Tdef Tei Tda
- 12. Electronic expansion valve PMV1
- 13. Low voltage sensor Ps1
- 14. High voltage sensor Pd1
- 15. Transformer secondary TR\_01
- 16. Transformer Primary TR\_IN

**Drive PCB 1122203000040 散热器模块组件 QD-3330(三菱 LNB53FCAMC)改压机-E1(SY)**

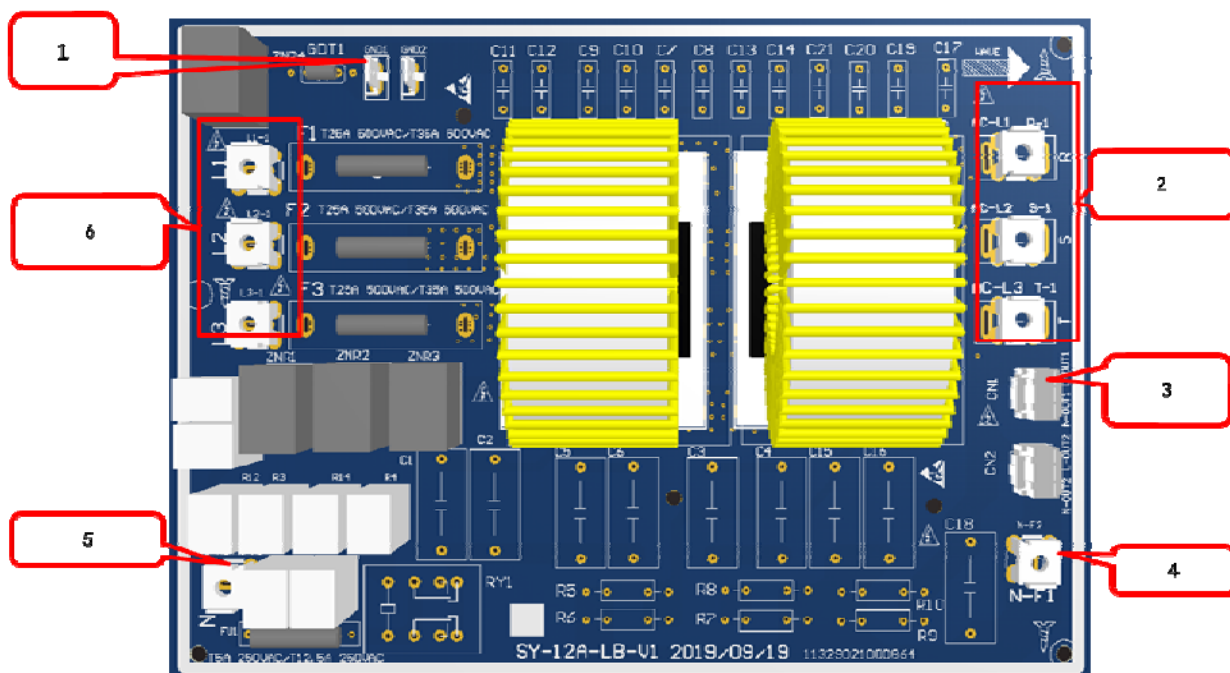

- 1. Ground Terminal
- 2. Drive board input R S T
- 3. Drive power supply L-OUT1 N-OUT1
- 4. Drive board input N
- 5. Power terminal board
- 6. Power terminal board input L1 L2 L3

Filter board 1122254800005 CJ 滤波板 LB-4318-1(SY)CJ

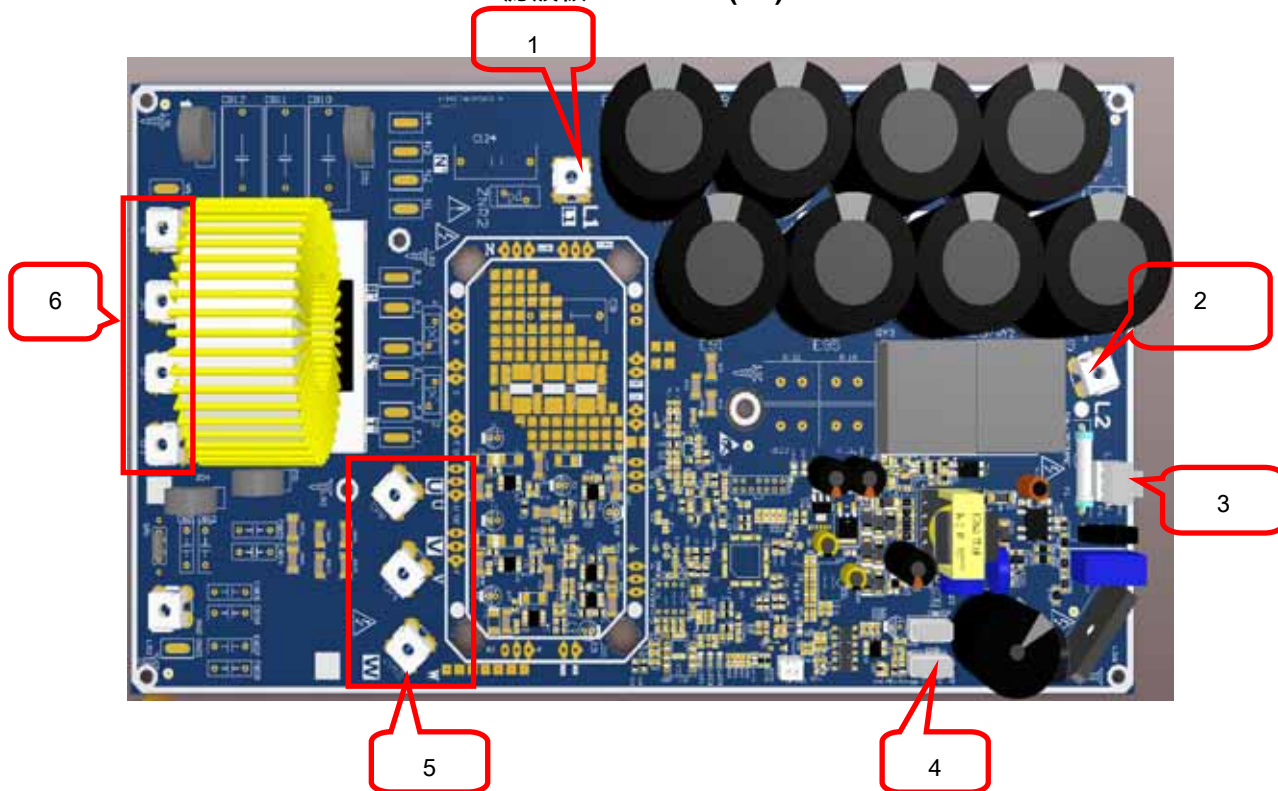

1. Reactor L1
2. Reactor L2
3. Power terminal L N
4. Inter-board communication C\_INV
5. Compressor U V W
6. Drive power input N R S T



### 4. DIP switch

#### 4.1 ARV-H80/NR1A, ARV-H100/NR1A, ARV-H120/NR1A, ARV-H140/NR1A, ARV-H160/NR1A

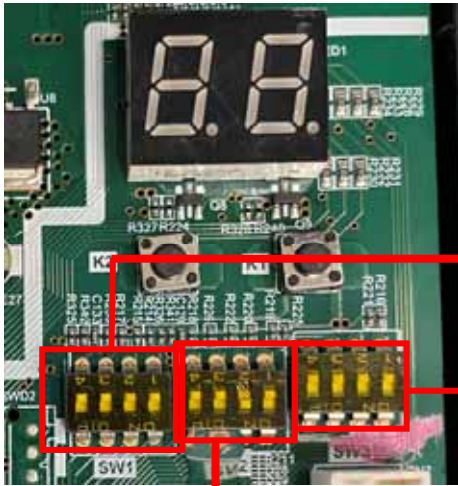

SW1	SW1	SW1	SW1	SW1
ON	ON	ON	ON	ON
1 2 3 4	1 2 3 4	1 2 3 4	1 2 3 4	1 2 3 4
8kW	10kW	12kW	14kW	16kW

SW2	1	1	26°C economic locking
		0	without 26°C economic locking(default)
	2	1	Auto addressing(default)
		0	Manual addressing
3	1	cool mode first	
	0	First match wins (default)	
4	1	Long connecting pipe (L)	
	0	short connecting pipe (S)(default)	

SW3	1	1	Mute at night
		0	Not mute at night(default)
	2	1	Undefined
		0	Undefined
3	1	Silent mode	
	0	Without silent(default)	
4	1	Locking indoor unit No.	
	0	Unlocking indoor unit No. (default)	

#### 4.2 ARV-H80/NR1, ARV-H100/NR1, ARV-H120/NR1, ARV-H140/NR1, ARV-H160/NR1

Capacity setting- SW1

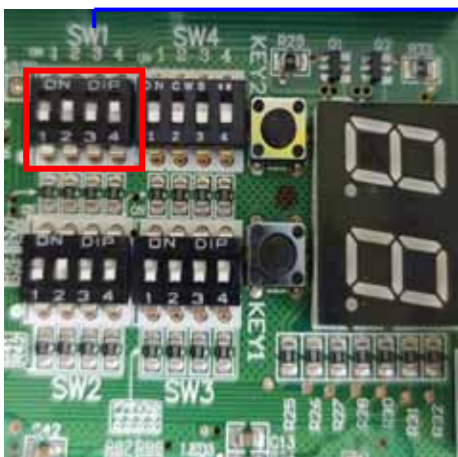

SW1	SW1	SW1	SW1	SW1
ON	ON	ON	ON	ON
1 2 3 4	1 2 3 4	1 2 3 4	1 2 3 4	1 2 3 4
8kW	10kW	12kW	14kW	16kW

Function setting- SW2

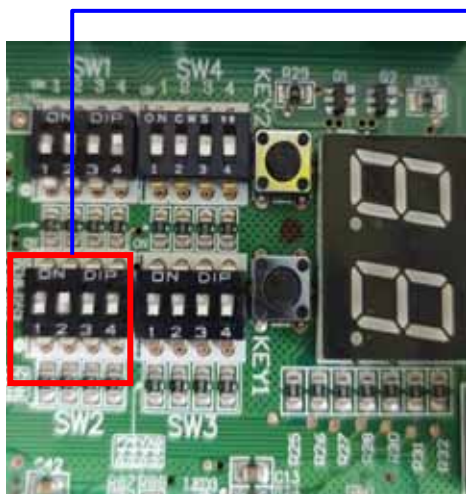

SW2	1	1	26℃ economic locking
		0	without 26℃ economic locking(default)
	2	1	Auto addressing
		0	Manual addressing
	3	1	cool mode first
		0	First match wins (default)
	4	1	AC Motor
		0	DC Motor

Function setting - SW3

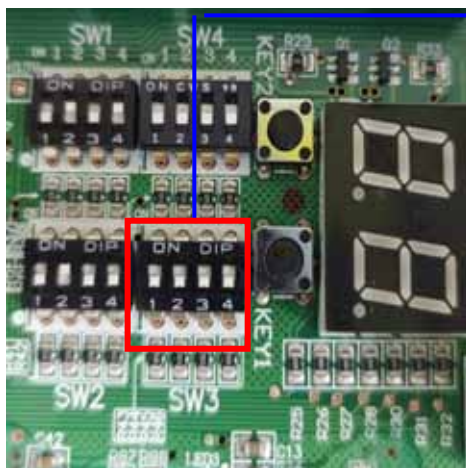

SW3	1	1	Undefined
		0	Undefined
	2	1	Without heating for 6hours after power on
		0	Heating for 6hours after power on
	3	1	Silent mode
		0	Without silent(default)
	4	1	Locking indoor unit No.
		0	Unlocking indoor unit No. (default)

Parameter checking- SW4

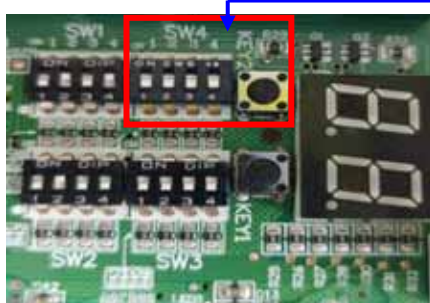

1. Long press "KEY2" button for 5s enter the parameter checking.
  2. Digital tube will display NO "F0", press "KEY2" again will turn to "F1", "F2"...
- If no action, 5s later will display the details (like the compressor frequency) and last for 1min.
3. Press the "KEY2" button while displaying the details, then will come back to NO.

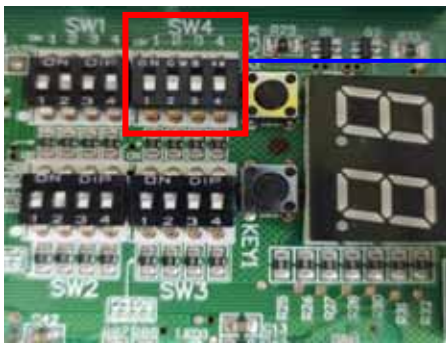

Model	SW4			
	1	2	3	4
R410	0	0	0	0
R32	0	0	0	1
Type A	0	0	1	0
Three phase power	0	0	1	1

4.3 ARV-H120/SR1DCS7、ARV-H140/SR1DCS7、ARV-H140/SR1DCSA、

ARV-H160/SR1DCS7、ARV-H160/SR1DCSA

Capacity setting- SW1

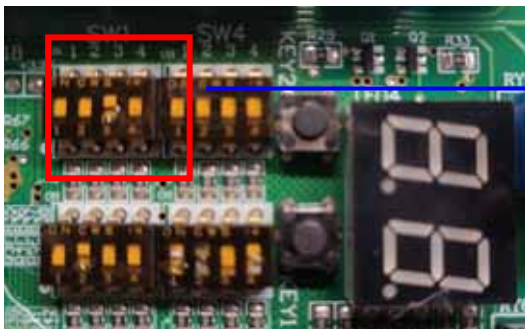

Capacity	SW1			
	1	2	3	4
8KW	0	0	0	0
10KW	0	0	0	1
12KW	0	0	1	0
14KW	0	0	1	1
16KW	0	1	1	1
18KW	0	1	0	1

Function setting- SW2

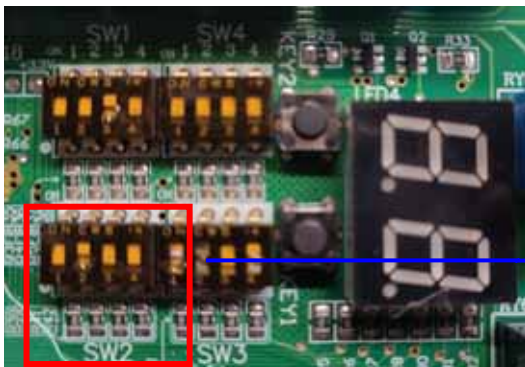

SW2	1	0	
			1
2	1	0	without 26°C economic locking (default)
	1	0	Auto addressing (default)
3	1	0	Manual addressing
	1	0	Majority rule
4	1	0	Automatic priority (default)
	1	0	AC Motor
			DC Motor

Function setting - SW3

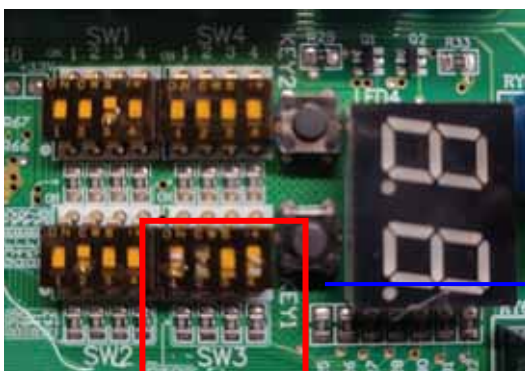

SW3	1	0	
			1
2	1	0	Without heating for 6hours after power on
	1	0	Heating for 6hours after power on (default)
3	1	0	Silent mode
	1	0	Without silent (default)
4	1	0	Locking indoor unit No.
	1	0	Unlocking indoor unit No. (default)

Parameter checking- SW4

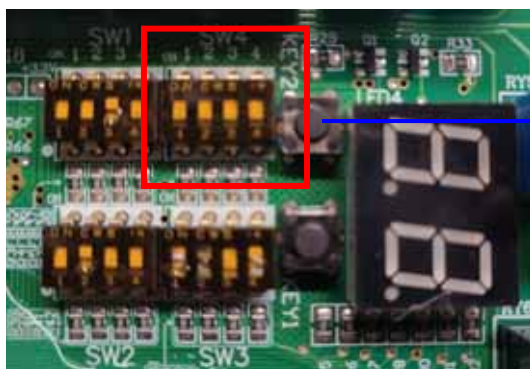

Model	SW4			
	1	2	3	4
R410	0	0	0	0
R32	0	0	0	1
Type A	0	0	1	0
Three phase power	0	0	1	1

#### 4.4 ARV- H220/SR1DCS7、 ARV- H260/SR1DCS7

Capacity setting- SW1

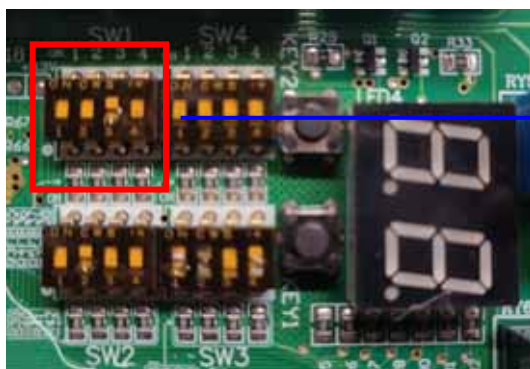

Capacity		SW1			
T1	T3	1	2	3	4
8kW		0	0	0	0
10kW	8kW	0	0	0	1
12kW	10kW	0	0	1	0
14kW	12kW	0	0	1	1
16kW	14kW	0	1	1	1
18kW		0	1	0	1
20/22.4kW	16kW	0	1	0	0
26kW	18kW	1	0	0	0
28kW		1	0	0	1
30kW		1	0	1	0
33.5kW		1	0	1	1
40kW		1	1	0	0
45kW		1	1	0	1
50.4kW		1	1	1	0

Function setting- SW2

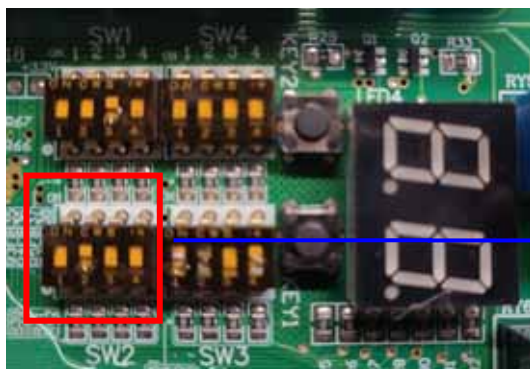

SW2	1	0	26℃ economic locking
		1	without 26℃ economic locking(default)
2	1	Auto addressing(default)	
	0	Manual addressing	
3	1	Majority rule	
	0	Automatic priority(default)	
4	1	AC Motor	
	0	DC Motor	

Function setting - SW3

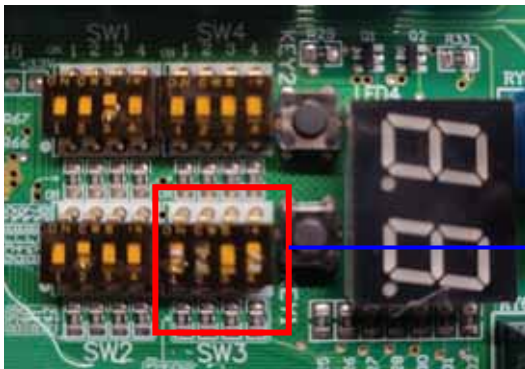

SW3	1	1	Undefined
		0	Undefined
	2	1	Without heating for 6hours after power on
		0	Heating for 6hours after power on(default)
	3	1	Silent mode
		0	Without silent(default)
	4	1	Locking indoor unit No.
		0	Unlocking indoor unit No. (default)

Parameter checking- SW4

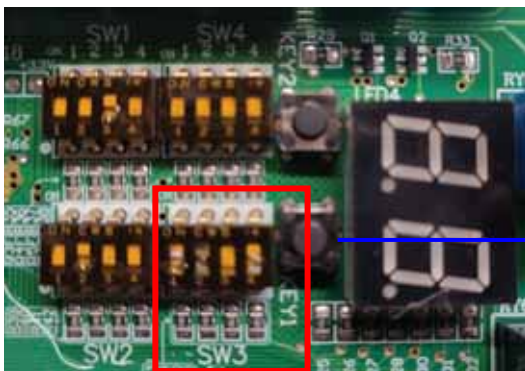

Model	SW4			
	1	2	3	4
R410	0	0	0	0
R32	0	0	0	1
Type A	0	0	1	0
Three phase power	0	0	1	1

4.5 ARV-H220/5R1A、 ARV-H280/5R1A

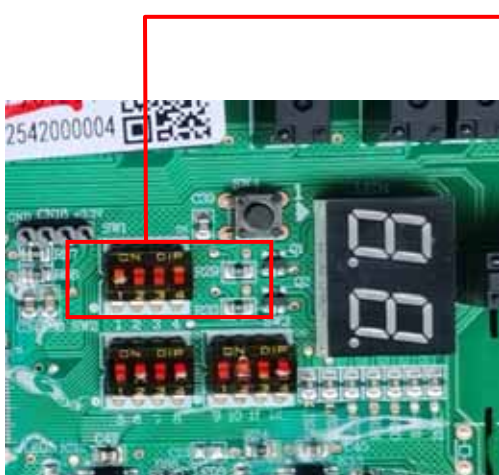

SW1 function definition: the unit capacity setting

Capacity	1	2	3	4	Capacity	1	2	3	4	Capacity	1	2	3	4
8KW	0	0	0	0	18KW	0	1	0	1	30KW	1	0	1	0
10KW	0	0	0	1	20KW	0	1	1	0	33.5KW	1	0	1	1
12KW	0	0	1	0	22.4KW	0	1	0	0	40KW	1	1	0	0
14KW	0	0	1	1	26KW	1	0	0	0	45KW	1	1	0	1
16KW	0	1	1	1	28KW	1	0	0	1	50.4KW	1	1	1	0

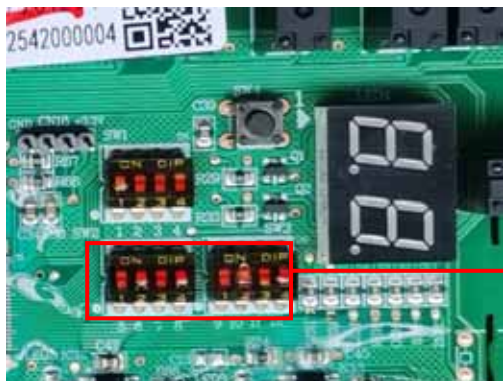

SW2 function definition: function selection		SW3 function definition: function selection	
1	1: 26℃ economic locking	1	1: Single phase unit
	0: without 26℃ economic locking (default)		0: Three phase unit (default)
2	1: Auto addressing	2	1: Without heating for 6 hours after power on
	0: Manual addressing (default)		0: Heating for 6 hours after power on (default)
3	1: cool mode first	3	1: Silent mode
	0: First match wins (default)		0: Without silent (default)
4	1: AC Motor	4	1: Locking indoor unit No.
	0: DC Motor		0: Unlocking indoor unit No. (default)

NO.	Definition	Remark(unit)
F0	Compressor Frequency	rps
F1	High pressure value	bar
F2	Discharge temperature	
F3	Defrosting temperature	
F4	Suction temperature	
F5	Oil temperature	
F6	1# fan speed	AC type(0,1,2,3),DC type(10 rpm)
F7	2# fan speed	AC type(0,1,2,3),DC type(10 rpm)
F8	EXV pulse	10 pulse
F9	Compressor current	A
F10(FA)	Driver module temperature	
F11(FH)	IDU total capacity	HP (3, 4, 5, 6...)
F12(FC)	ODU operation mode	Standby(00),cooling(C0),heating(HE)
F13(FJ)	Version number	/
F14(FE)	Reserve	/

### 5. Commissioning

Before all steps of setting , keep the system power on and standby , after setting , restart the whole system

### 3.1 Check capacity setting

1. Check the nameplate's capacity and the capacity setting in main PCB's dip switch. If not the same, you should change the setting

2. For example: nameplate's capacity is "16kw" but the "SW1" dip switch setting is "", through check the "[2.1 Capacity setting- SW1](#)", find out setting capacity was "8kw", so should

change the switch to ""

### 3.2 Check fan motor setting

1. Check the fan motor's type, through the fourth switch in "SW2"

2. For example: if the ODU's fan motor is **DC type**, through check the "[2.2 Function](#)

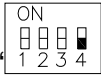
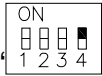
[setting-SW2](#)" ,so should be set to ""; **AC type** should be set to "

### 3.3 Preheating 6 hours setting

1. Preheating 6 hours function is factory default, this function is used for heating mode in low ambient temperature, and the system will operation after 6 hours

2. So when system used for cooling mode, you can cancel preheating 6 hours function, it does not affect the operation and no need wait for 6 hours, through the second switch in

"SW3" check the "[2.3 Function setting-SW3](#)" ,then set to "

### 3.4 IDU address setting

1. Before IDU address setting, should unlock IDU's quantity through the fourth switch in

"SW3" check the "[2.3 Function setting-SW3](#)" then set to "

2. After set, through the second switch in "SW2" choose IDU address setting function, check

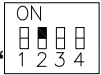
the "[2.3 Function setting-SW2](#)", "Auto addressing" set to "

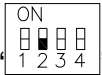
indoor address, "Manual addressing" set to "

remote or wired controller

3. After above 2 steps, restart the whole system then the digital tube (LED) in main PCB will display quantity of indoor units, check is it consistent with the actual installation quantity, if it is not consistent detect the communication between IDU and ODU

4. If consistent then should lock IDU's quantity through the fourth switch in "SW3" check

the "2.3 Function setting-SW3" then set to "  ", the whole commissioning complete



## 6. IDU Parameter setting by Controller

### 6.1 Parameter Setting Items

No.	Parameter Setting Items	Default value	Min. value	Max. value	Remark
1	communication address of indoor unit	1	1	64	
2	centralized address of indoor unit	1	1	64	
3	address of wired controller of indoor unit	1	1	16	
4	model of indoor unit	1	0	36	<p>1. When replacing the PCB board, first record the parameters of the previous PCB board, and then set the parameters to the corresponding new PCB.</p> <p>2. When the PCB board is broken, you</p>



					<b>need to provide the machine nameplate to our company, and our company will provide the corresponding parameters, and then set the parameters to the corresponding new PCB.</b>
5	capacity of indoor unit	8	1	100	280W/unit
7	selection of room silent mode	0	0	1	0--normal 1--silent mode
8	auto restart function of indoor unit	1	0	1	0—Available 1--not available
9	room card selection	0	0	6	/
10	clearing time of filter net	5	1	99	100h/unit
11	operating mode displayed by wired controller	1	0	2	0--[auto][heating] [dehumidification][cooling][ventilation] 1--[heating] [dehumidification][cooling][ventilation] 2--[dehumidification][cooling][ventilation]
12	installation height of indoor unit	0	0	1	0-- installation height is lower than 2.7m 1--installation height is higher than 2.7m
13	switching between Celsius degree and Fahrenheit	0	0	1	0--Celsius degree 1--Fahrenheit
14	display of room temperature	0	0	1	0-- room temperature not to be displayed 1-- room temperature to be displayed
15	selection of room temperature	0	0	1	0-- temperature sensor of return air 1--temperature sensor of wired controller

## 6.2 Parameter setting by YK – L

### 6.2.1 Enter the setting interface

Make sure the remote controller is off

Press the two white button at the down side simultaneously more than 10s to enter the address setting mode.

First, will display“1”,“1”,

the above number means : Series parameter number from 1~15

the below number means : Meaning of parameter correspondence

#### For example:

Check “6.1 Parameter Setting Items” for number of parameters and corresponding meaning.

“1”,“1”: The indoor unit’s address is 1#

“4”,“32”: The indoor unit’s type is Wall - Mounted (L Type )



### 6.2.2 Parameter Setting

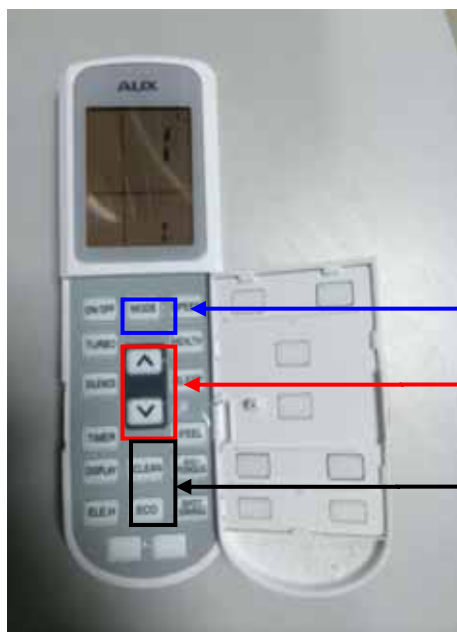

Press “**MODE**” button to send order; When hearing buzzer once, it indicates successful setting

Press the “**up**” or “**down**” button to change the parameter series number

Press the “**Iclean**” or “**ECO**” button to change the parameter correspondence

### 6.3 Parameter setting by XK-05A

#### 6.3.1 Enter the setting interface

Press “**Function**” button for 10 s to enter the setting interface.

“**0303**” means address of wired controller of indoor unit. Check “6.1 Parameter Setting Items” for number of parameters and corresponding meaning.

“**03**”: series parameter number from 1~15

“**03**”: parameter correspondence



Press the “**Function**” to enter

#### 6.3.2 Change series parameter number

Press “up” /”down” button to change the number.

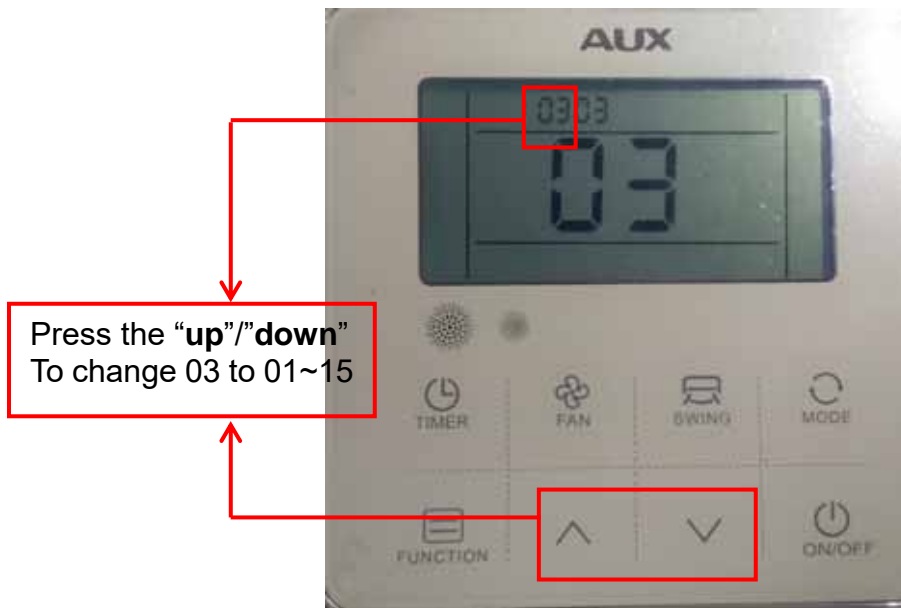

**6.3.3 Parameter correspondence setting.**

Press “Function” button , the second “03” will flash  
Press “up” /”down” button to change the number  
press [Function Button] to confirm

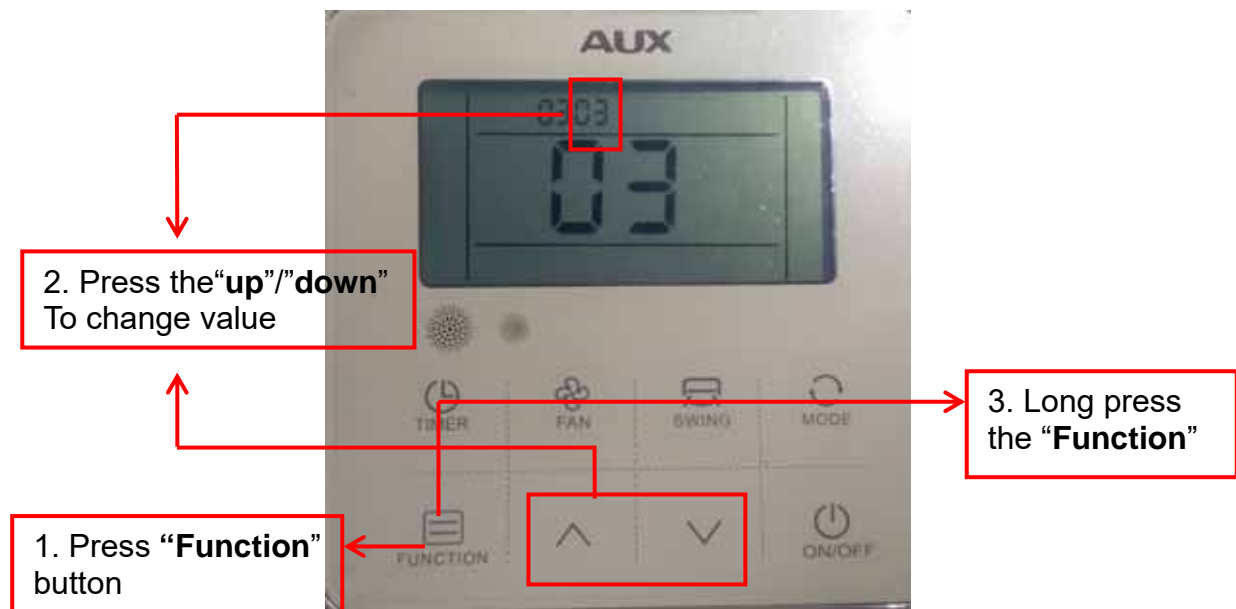

## Part6 Function and Control

### 1. Compressor control

#### 1.1 Compressor type:

Rotary DC inverter compressor

#### 1.2 Start-up control:

The minimum operation time of compressor is 6 minute, after compressor start to work, which means it cannot stop working immediately if the working time is less than 6 minute except shutdown by failure. Similarly, the compressor will not restart until more than 3 minute after stop operation

#### 1.3 Operation control:

The compressor can auto-adjust its frequency according to the target evaporating temperature (on cooling mode) and target condensing temperature (on heating mode) to get the target value.

#### 1.4 Protection adjustment control:

2.4.1 High pressure control (cooling mode) :

When the high pressure value  $P_d < 25\text{bar}$ , the compressor will regulate its frequency according to target evaporating temperature.

When the high pressure value  $25\text{bar} \leq P_d < 40\text{bar}$ , the compressor will regulate its frequency to match with target high pressure value 38bar, 10s as a adjustment cycles.

When the high pressure value  $P_d \geq 40\text{bar}$  and lasts 10s. Indoor and outdoor will stop running and display an error code which means high pressure value too high to protect

#### 2.4.2 High pressure control (heating mode) :

When the high pressure value  $P_d < 28\text{bar}$ , the compressor will regulate its frequency according to target condensation temperature.

When the high pressure value  $28\text{bar} \leq P_d < 39\text{bar}$ , the compressor will regulate its frequency to match with target high pressure value 28bar, 10s as a adjustment cycles.

When the high pressure value  $P_d \geq 39\text{bar}$  and lasts 10s. Indoor and outdoor will stop running and display an error code which means high pressure value too high to protect

## 2. Fan motor control

### 2.1 Motor type:

The DC brushless fan motor which with 10 kinds of motor speed mode.

### 2.2 Control function:

Fan motor fault: if fan motor running speed out of range ( normal range from 70% to 130%) and last for 120s, or fan motor speed lower than 200rpm and last for 120s, then whole system will stop running and display an error code which means fan motor fault. After 120s will recover normal running mode, if this error code display 6 times within 1 hour, then this error code will be locked.

When compressor stops running, fan motor will keep previous running statue for 1 minute then stop.

Cooling mode, fan motor's running speed will increase and reduce according to the detect high pressure value's increase and reduce

Heating mode, fan motor's running speed will change according to the detect condenser's superheat degree, when superheat degree lower than normal value, fan

motor's running speed will increase, when superheat degree higher than normal value, fan motor's running speed will reduce

### 3. Four-way valve Control

Four-way valve will be **OFF** when cooling and dehumidifying and it will be on when heating.

Heating mode: Four-way valve will be **NO** after compressor running about 30s

Shutdown in heating mode: four-way valve will keep **NO** When ambient temperature lower than 25 , four-way valve will be **OFF** after an hour when ambient temperature higher than 25

Four-way valve will be **OFF** when operation cooling / dehumidifying / defrosting / oil return mode

### 4. Compressor preheating control

When compressor in standby state and standby time over than 1 hour and less than 240h, then start up compressor preheating function

### 5. Defrost control

#### 5.1 Defrosting condition

Heating mode: According to detect running time of compressor / defrost temperature of condenser / high pressure value to judge whether enter defrost

#### 5.2 Defrosting

Heating mode → The preparation of defrosting (20Hz , 40S)→defrosting→Complete defrosting (20Hz , 40S) → Heating mode

#### 5.3 Exit condition

Defrosting will be finished if any requirements below are satisfied.

6.3.1 Defrost temperature of condenser higher than 10 and last for 1 minute, or higher than 12 and last for 30 s

6.3.2 High pressure value higher than 30 bar

6.3.3 Discharge temperature higher than 100

6.3.4 Total defrosting time more than 10 minutes

## 6. Oil return control

### 6.1 Oil return condition

Compressor running frequency lower than the setting frequency and last for 4 hours

### 6.2 Oil return

#### 7.2.1 Cooling mode

Cooling mode → Oil return running (65Hz) → Cooling mode

#### 7.2.2 Heating mode

Heating mode → The preparation of oil return (20Hz , 40S)→oil return running→

Complete oil return (20Hz , 40S) → Heating mode

### 6.3 Exit oil return

Oil return will be finished if any requirements below are satisfied.

6.3.1 After running 2 minutes, if discharge temperature higher than 100

6.3.2 After running 2 minutes, if high pressure value higher than 34 bar

6.3.3 Oil return running last for 3 minutes

## 7. EXV control

7.1 Initialization: EXV will be initialized when turning on at the first time.

7.2 EXV will not be reset when turning on/off unless the downtime of it is more than 24h.

7.3 EXV Control info is as follows.

Mode	Status	Open degree	Instruction
Cooling	Operation	480	Unchanged
	Standby	0	Unchanged
Heating	Operation	65~480	Self-adjusting according to the degree of suction temperature superheat
	Standby	0	Unchanged

## 8. Protection control

### 8.1 Pressure switch protection

Disconnection pressure value of high pressure switch: 4.2MPa±0.05Mpa



Connection pressure value of high pressure switch: 3.3MPa±0.05Mpa

Disconnection pressure value of low pressure switch: 0.1MPa±0.05Mpa

Connection pressure value of low pressure switch: 0.15MPa±0.05Mpa

## 8.2 Discharge temperature too high control

When the discharge temperature lower than 80 , compressors will auto-adjust its frequency

When the discharge temperature is equal to or higher than 80 , but lower than 115 , the frequency of compressor will be adjusted limitedly

When the discharge temperature higher than 115 and last for 10s, compressors will stop running and display an error code, after 3 minutes will recovery to the previous status. But if the error code display 3 times within 1 hour then this error code will be locked unless it is solved.

## 8.3 Discharge temperature too low control

When the superheat of discharge temperature lower than 3 and last for 15minutes, compressors will stop running and display an error code, after 3 minutes will recovery to the previous status. But if the error code display 3 times within 1 hour then this error code will be locked unless it is solved.

## 8.4 Communication fault between IDU and ODU

ODU cannot receive any signal from any indoor units within 1 minute, then will stop running and display an error code (Communication failure protection). It can recovery automatically when the communication between IDU and OUD is good.

## 8.5 Module failure protection

Units shut down immediately when IPM Module failure happened, which can be recovered.

## 8.6 Temperature of IPM too high protection

The units will stop working when the IPM temperature checked is higher than the setting value. It will recovery automatically after 3min.If this kind of situation happened 6 times within 1h, units will be locked and cannot work regularly unless it is solved.

## 8.7 Capacity ratio out of range

When the capacity ratio (total capacity of IDUs / capacity of ODU) over than 130% then will display an error code and be locked once happen.

## Part7 Trouble shooting

### 1. Poor effect of cooling and heating

Some phenomenon in using process is similar to failures, which are not failures in fact. Therefore, when cooling performance isn't satisfactory, eliminate the following factors first:

Phenomenon	Cause Description
If there is high ambient temperature outside and more people in room, air conditioner works in full load and cool air is blown from outlet, but room temperature can't be lowered.	In case of high ambient temperature, infiltration heat from outside increases, which increases cooling load of air conditioner; if there are more people (e.g.10 people) in room, each people discharges 120W heat, 10 people discharge 1200W heat altogether, which consume half cooling capacity of air conditioner, therefore, cooling capacity of air conditioner seems not enough and room temperature can't be lowered. It's normal and not the fault of air conditioner.
Air conditioner is hard to start, stops after starting or fuse is blown due to under voltage of power supply.	It is not failure. It's necessary to check the cause of power supply. If it is caused by under voltage of power grid, user should install additional voltage stabilizer for power supply to enable voltage to reach 220V or 380V and use air conditioner normally.

When it operates under high air velocity, room temperature can't cool down and there is no much air flow volume at outlet.	Filth blockage of air filter makes cooling capacity can't be taken out by flowing air timely, causing insufficient cooling capacity that can be solved by removing and cleaning filtering net.
When it operates under high air velocity, unit vibrates and makes loud noise	It is normal that the unit vibrates and makes loud noise when it operates in maximum speed.
Temperature controller isn't properly adjusted and doesn't bring maximum function of cooling, so room temperature can't cool down.	Adjust temperature controller to solve the problem
Heat pump-type air conditioner has unsatisfactory heating effect in cold winter, which is reasonable.	Minimum ambient temperature for starting heating function of air conditioner is -15 .So air conditioner can't effectively heat below this temperature.
Improper installation position of air conditioner can also result in uneven indoor temperature or poor cooling effect.	Readjust the installation position of air conditioner.
mist blown out from indoor unit	It is caused when cool airflow in air conditioner cools down the air in indoor unit.
noise	Air conditioner will make noise when stopping operation, because refrigerant in the unit flows to opposite direction;
	Air conditioner will expand or shrink due to air temperature change, causing harsh sound; sound of water flow is caused by refrigerant flowing in the unit.
odor in room sometimes	Air conditioner won't bring odor by itself, so it must be caused by odor accumulated in environment.
	Solution: clean air filtering net.
In case of heating, air isn't blown out immediately after starting the unit and "Operation" indicator flickers when wired controller is used.	The heating state is used to prevent blowing out cool air. Please wait for a moment.
	The unit has restart function upon power-on after power failure. Air conditioner will automatically start in case of power-on after power failure and operate according to the mode set before power failure.

## 2 . IDU Fault code table

Serial	Error code	Error code definition	Recovery or not	Problem possible reasons
1	A1	Indoor ambient temperature sensor failure	Yes	Indoor PCB is broken
				The fuse of indoor PCB is broken
				temperature sensor broken , or exceed test limit
2	A2	Temperature sensor about middle position of evaporator failure	Yes	Indoor PCB is broken
				The fuse of indoor PCB is broken
				temperature sensor broken , or exceed test limit
3	A3	Indoor coil pipe inlet temperature sensor failure	Yes	Indoor PCB is broken
				The fuse of indoor PCB is broken
				temperature sensor broken , or exceed test limit
4	A4	Indoor coil pipe outlet temperature sensor failure	Yes	Indoor PCB is broken
				The fuse of indoor PCB is broken
				temperature sensor is broken , or exceed test limit
5	A5	Indoor water pump failure	Yes	Water pump no power
				Water pump switch short-circuit or unconnected
				Water pump is broken
				Drain pipe block or up lean
				Indoor PCB is broken
6	A6	Failure of indoor PG fan	No	Fan motor failure
				Fan motor block
				The connection between PCB and fan motor failure.
				Indoor fan block
7	A7	Failure of reversible synchronous motor	No	Step motor failure
				The connection between PCB and step motor failure.
8	A8	Indoor unit ERRPROM module failure	No	Indoor unit PCB is broken
				Error module is broken.

9	<b>A9</b>	The communication between indoor unit and outdoor unit failed	No	The communication wire between indoor unit and outdoor unit is broken.
				Indoor unit power close
				Indoor PCB is broken
10	<b>AA</b>	The communication between indoor unit and wire controller failed	No	The communication wire between indoor unit and outdoor unit is broken.
				Indoor unit power close
				Indoor PCB is broken
				Wire controller is broken
11	<b>AC</b>	Two or more indoor unit central control system address repeated	Yes	The central control address setting incorrect
12	<b>AE</b>	Operation mode conflict	Yes	The operation mode setting incorrect
13	<b>AH</b>	Two or more indoor unit refrigerant system address repeated	Yes	System address setting incorrect
14	<b>AJ</b>	Indoor unit total capacity exceeded	Yes	Stop some indoor units
15	<b>AF</b>	The EXV leakage	Yes	EXV is blocked
				Indoor unit temperature sensor issue.
				Evaporator inlet sensor failure.
16	<b>A0</b>	The EXV to open failure	No	
17	<b>99</b>	Communication failure between internal machine and fan drive board	Yes	Drive board, power supply shall not be electrified
				Communication lines are not connected or loose
				Module board failure
18	<b>9A</b>	Indoor fan module temperature protection	Yes	The temperature of the inner fan module is too high
19	<b>9H(9B)</b>	The Indoor fan module fails to start or runs out of step	No	There is foreign matter in the indoor cavity or the fan blade screw is loose
				The motor model set in the internal machine does not match the actual indoor motor Model
				Module board failure

				Motor failure
20	9C	Overcurrent protection of Indoor fan	No	Internal parameters static pressure setting is relatively large
				There is foreign matter in the indoor cavity or the wind vane screw is loose
				Internal machine setting motor model does not match the actual indoor motor Model
				Module board failure
				Motor failure
21	9J(9D)	DC overvoltage protection of Indoor fan	No	The fan line is not connected or loose
				Module board failure
				Motor failure
22	9E	Indoor fan driver board IPM alarm	No	Internal parameters static pressure setting is relatively large
				There is foreign matter in the indoor cavity or the wind vane screw is loose
				Internal machine setting motor model does not match the actual indoor motor Model
				Module board failure
				Motor failure
23	9F	Indoor fan drive board EE fault	No	Module board failure, unable to read EE parameter after power-on
				EE parameter is manually changed

### 3. ODU Fault code table

Serial	Error Code	Error code definition	Recovery or not	Possible reason
1	F3	High pressure too high protection "Pd"	Yes	Exhaust pipe or condenser pipe block
				Condenser dirty
				Outdoor unit fan stop or low speed
				Refrigerant overcharge

2	F6	Low pressure too low protection "Ps"	No	Indoor unit fan stop or low speed
				Evaporator dirty
				Indoor EXV full open in cooling mode (Outdoor EXV full open in heating mode)
				Lack refrigerant
				The pipe between evaporator and suction port block
3	FH (FB)	Discharge temperature "Tdi" too low limit frequency protection	No	Once confirm the unrecoverable
4	H1 (B1)	High pressure switch failure "HPSa"	No	System pressure exceed high pressure switch limit.
				High pressure switch failure
				High pressure sensor failure
				Instantaneous power-off
				Stop valve closed
				Outdoor unit fan stop
				Outdoor unit air outlet block
				In heating mode indoor unit fan stop
				In heating mode indoor unit EXV block
5	H4(B4)	Low pressure switch failure "HPSa"	NO	System pressure exceed high pressure switch limit.
				Low pressure switch failure
				Low pressure sensor failure
				Instantaneous power-off
				Stop valve closed
				Outdoor unit fan stop
				Outdoor unit air outlet block
				In heating mode indoor unit fan stop
				In heating mode indoor unit EXV block
6	H5	Refrigerant shortage fault	No	System leakage
7	HJ	Main power failure	No	Supply power phase-reversal
				Supply power phase lack
				Outdoor unit PCB failure

8	E3	No.1-DC Compressor "Tda" discharge temperature too high shutdown protection	No	<ol style="list-style-type: none"> <li>1.System less refrigerant</li> <li>2.DC inverter Compressor failure</li> <li>3.Compressor air return filter block</li> <li>4.EXV open degree is small</li> <li>5.EXV block</li> <li>6.Gas pipe stop valve closed</li> <li>7.Liquid pipe stop valve closed</li> <li>8.System exhaust sensor failure</li> <li>9.Outdoor unit PCB failure</li> </ol>
9	J7	Outdoor unit main control PCB ERRORM module failure	No	Mail PCB failure
10	JJ	Indoor unit total capacity exceeding	Yes	Indoor units' total capacity over 130% of the outdoor units' total capacity
11	47	Indoor unit loss failure	Yes	Communication wire between indoor units failure
				Indoor PCB failure
				Power supply of indoor units failure
12	E1	The 4-way valve is fault	NO	/
13	E9	Drive refrigerant cooling pipe low temperature protection	NO	/
14	C1	Ambient "Tao" temperature sensor failure	Yes	<ol style="list-style-type: none"> <li>1.Temperature sensor failure</li> <li>2.Test temperature exceed limit</li> <li>3.Sensor connection is incorrect</li> <li>4.Outdoor unit PCB failure</li> </ol>
15	C2	Defrosting "Tdef" temperature sensor failure	Yes	
16	C3	Compressor 1# discharge "Tda" temperature sensor failure	Yes	
17	C6	Suction pipe of compressor "Ts" temperature sensor failure	Yes	



18	<b>C8</b>	Condenser Mid temperature sensor failure	Yes	
19	<b>CJ</b>	Oil "Toila" temperature sensor failure	Yes	
20	<b>F1</b>	High pressure sensor failure "Pd"	Yes	High pressure sensor failure
				High pressure sensor connection is incorrect.
				Outdoor unit PCB failure
21	<b>F4</b>	Low pressure sensor failure "Ps"	Yes	Low pressure sensor is broken.
				The connection between sensor and outdoor PCB incorrect
				Outdoor unit PCB failure
22	<b>J2</b>	Communication failure between outdoor and indoor unit	Yes	The communication wire between indoor unit and outdoor unit disconnect, short circuit or connect incorrect.
				Indoor unit main power failed
				Indoor unit PCB failure
23	<b>J3</b>	Communication failure between PCB and INV drive module	Yes	The connection between driving module and main PCB failure
				The communication part of outdoor unit control PCB failure
				Frequency driving board failure
				Compressor failure
24	<b>J4</b>	Communication failure between main PCB and DC fan motor drive module	Yes	DC fan motor drive module failure
				DC fan failure
25	<b>31</b>	Compressor 1# drive Module IPM protection (F0)	Yes	1. Supply voltage below level let the current excessive 2. Supply voltage exceed limit 3. Outdoor fan stop or low speed 4. Drive module temperature too high
26	<b>32</b>	Compressor 1# drive Module hardware protection	Yes	
27	<b>33</b>	Compressor 1# drive Module software	Yes	

		protection		
28	34	Compressor 1# drive module unconnected	Yes	The connect of driving module and DC inverter compressor incorrect
				Driving module failure
				Compressor failure
29	35	Compressor 1# phase current overload protection	Yes	Compressor overload
				Compressor coil disconnect
				Inverter driving board failure
				Compressor failure
30	36	Compressor 1# DC bus voltage over-voltage or under-voltage failure	Yes	Supply voltage below level
				Supply voltage exceed limit
				Driving module failure
31	37	Compressor 1# temperature sensor of drive module heat fins failure	No	Inverter driving board failure
32	38	Compressor 1# drive module high temperature limit frequency failure	Yes	Driving module failure
				Compressor failure
				Outdoor unit fan stop or low speed
33	39	Compressor 1# drive module high temperature shutdown protection	Yes	Driving module failure
				Compressor failure
				Temperature sensor failure
34	3E	Compressor 1# drive module AC Input over current protection	No	Once confirm the unrecoverable
35	3F	Compressor 1# drive Module PFC protection (F0)	Yes	/
36	3H(3B)	DC fan 1 module startup failure or running out of step	Yes	<ol style="list-style-type: none"> <li>1. Loose fan blade screws, abnormal air inlet or overstocking of snow</li> <li>2. Incorrect external capacity setting (Dialing) or incorrect model setting (Dialing)</li> <li>3. fan controller EE parameter does not match the actual motor Model</li> <li>4. Module board failure</li> <li>5. Motor failure</li> </ol>

37	<b>HE(BE)</b>	High AC input voltage protection of unit	Yes	<ol style="list-style-type: none"> <li>1. Unstable voltage</li> <li>2. Abnormal connection</li> </ol>
38	<b>3C</b>	DC fan 1 overcurrent protection	Yes	<ol style="list-style-type: none"> <li>1. Loose fan blade screws, abnormal air inlet or overstocking of snow</li> <li>2. Incorrect external capacity setting (Dialing) or incorrect model setting (Dialing)</li> <li>3. fan controller EE parameter does not match the actual motor Model</li> <li>4. Module board failure</li> <li>5. Motor failure</li> </ol>
39	<b>3J(3D)</b>	DC fan 1DC over-voltage protection	Yes	<ol style="list-style-type: none"> <li>1. The fan line is not connected or loose</li> <li>2. Module board failure</li> <li>3. Motor Failure</li> </ol>
40	<b>43</b>	DC Fan 1 driver board hardware protection	No	<ol style="list-style-type: none"> <li>1. Module board failure, unable to read EE parameter after power-on</li> <li>2. EE parameter is manually changed</li> </ol>
41	<b>4H(4B)</b>	DC Fan 2 driver board hardware protection	No	<ol style="list-style-type: none"> <li>1. Module board failure, unable to read EE parameter after power-on</li> <li>2. EE parameter is manually changed</li> </ol>
42	<b>5H(5B)</b>	DC Fan 2 module startup failure or running out of step	Yes	<ol style="list-style-type: none"> <li>1. Loose fan blade screws, abnormal air inlet or overstocking of snow</li> <li>2. Incorrect external capacity setting (Dialing) or incorrect model setting (Dialing)</li> <li>3. fan controller EE parameter does not match the actual motor Model</li> <li>4. Module board failure</li> <li>5. Motor failure</li> </ol>
43	<b>5C</b>	DC Fan 2 overcurrent protection	Yes	<ol style="list-style-type: none"> <li>1. Loose fan blade screws, abnormal air inlet or overstocking of snow</li> <li>2. Incorrect external capacity setting (Dialing) or incorrect model setting (Dialing)</li> <li>3. fan controller EE parameter does not match the actual motor Model</li> <li>4. Module board failure</li> <li>5. Motor failure</li> </ol>
44	<b>5J(5D)</b>	DC Fan 2 DC over-voltage protection	Yes	<ol style="list-style-type: none"> <li>1. The fan line is not connected or loose</li> <li>2. Module board failure</li> <li>3. Motor Failure</li> </ol>

## 4. Error code display

### 4.1 Error code display by wired control – YK-05A



“ **E0A1** ” means the first error code “**A1**”, through the “2.1 IDU Fault code table” to check error code definition

“**E2A3**” means the second error code is “**A3**”

Press “ **Function** ” “**Up**” button at the same time to enter the error code check

### 4.2 Error code display by digital tube – panel

“**E0**” error code



### 4.3 Outdoor unit error code display

For outdoor units, the error code displays on the main PCB (Master unit).

**Outdoor unit main PCB**

**Outdoor unit main PCB**

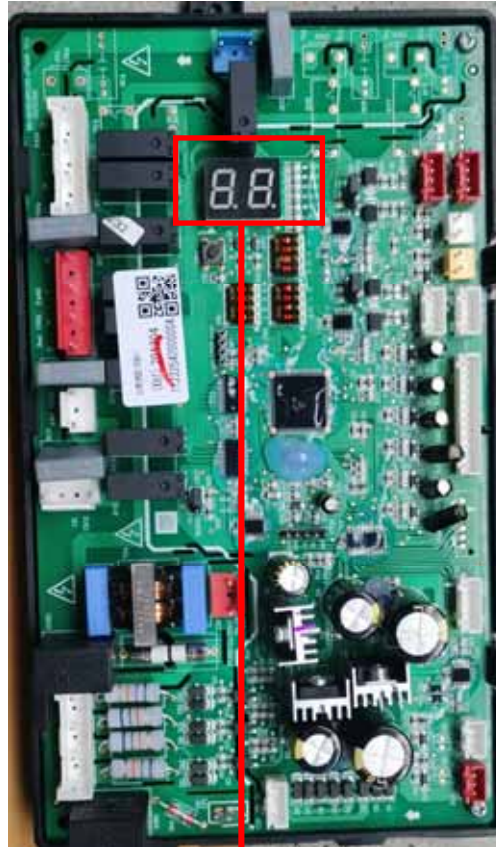

Error code “H5”, through the “[2.2 ODU Fault code table](#)” to check the definition: system leakage

## 5. Outdoor unit trouble shooting

### 5.1 F3 Error Code

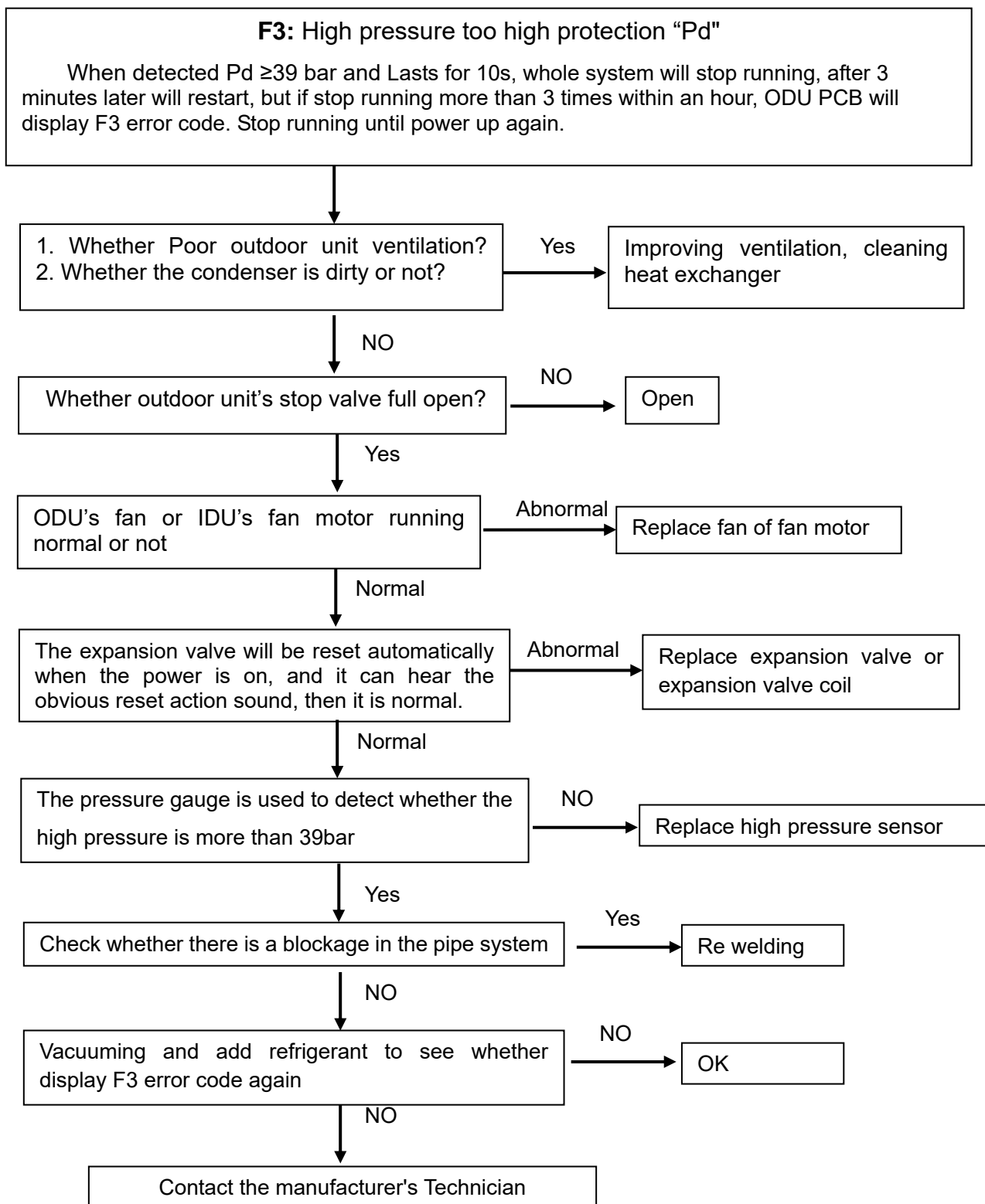

5.2 H1 Error code

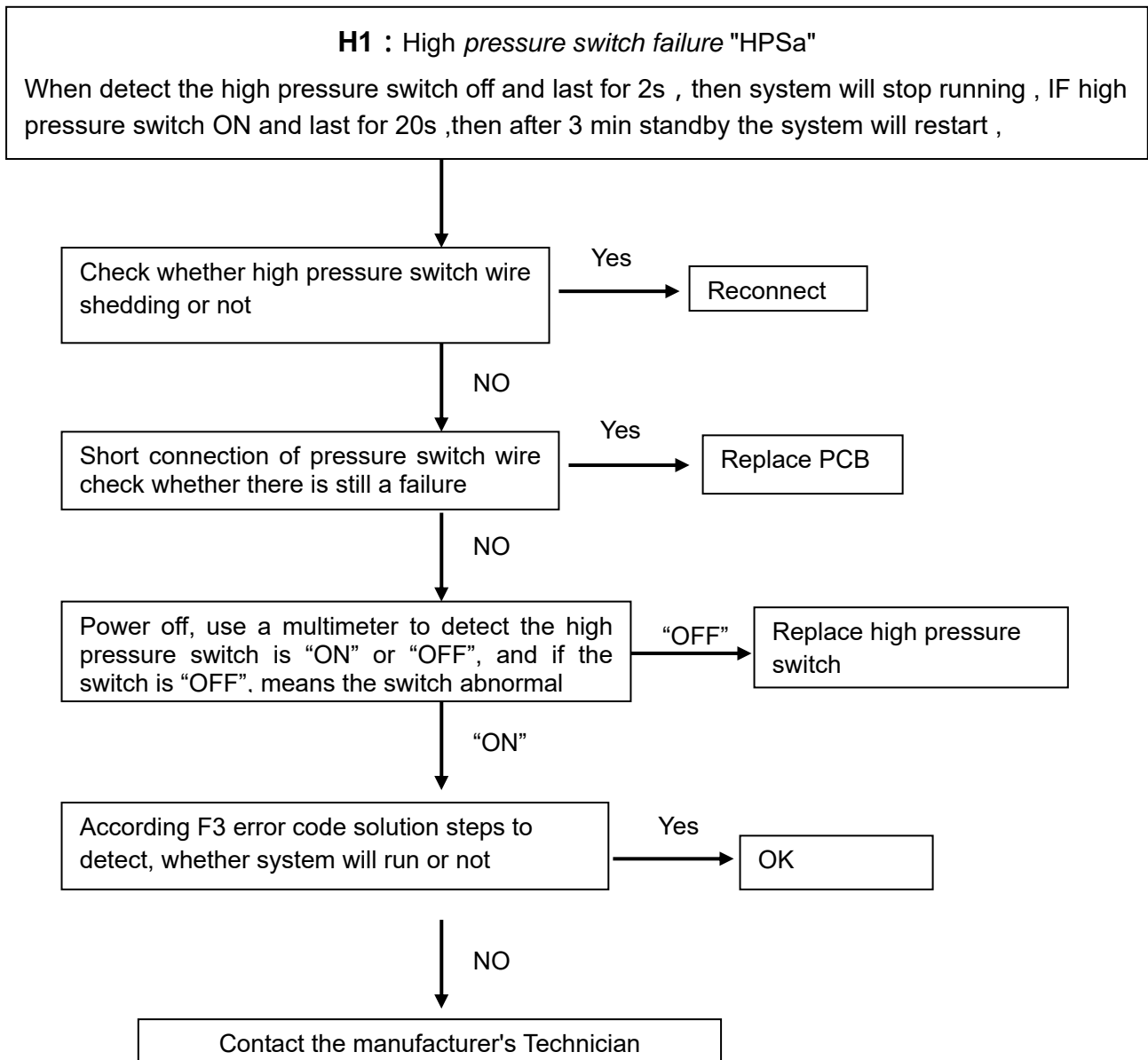



5.3 H4 Error code

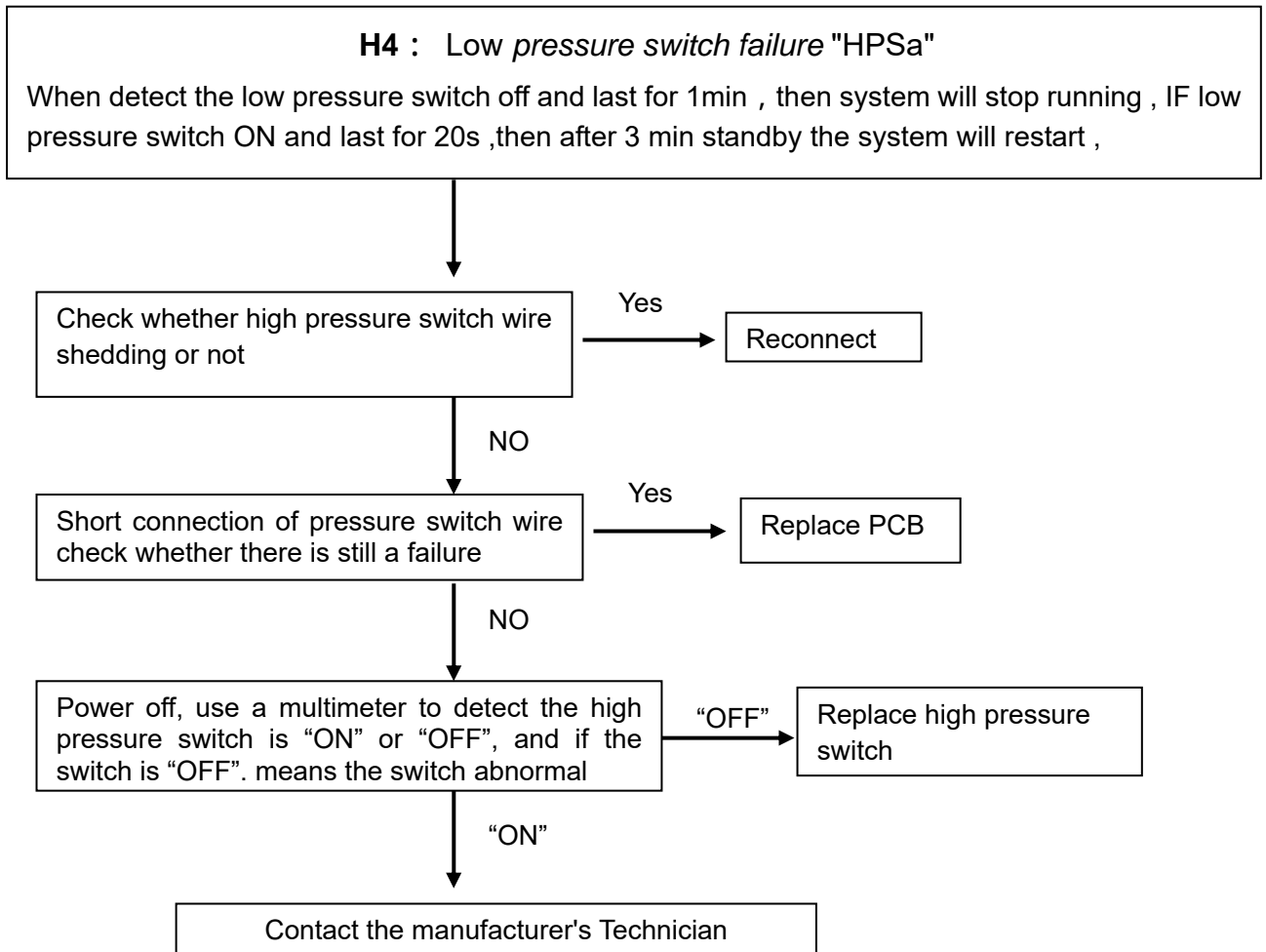

5.4 E1 Error code

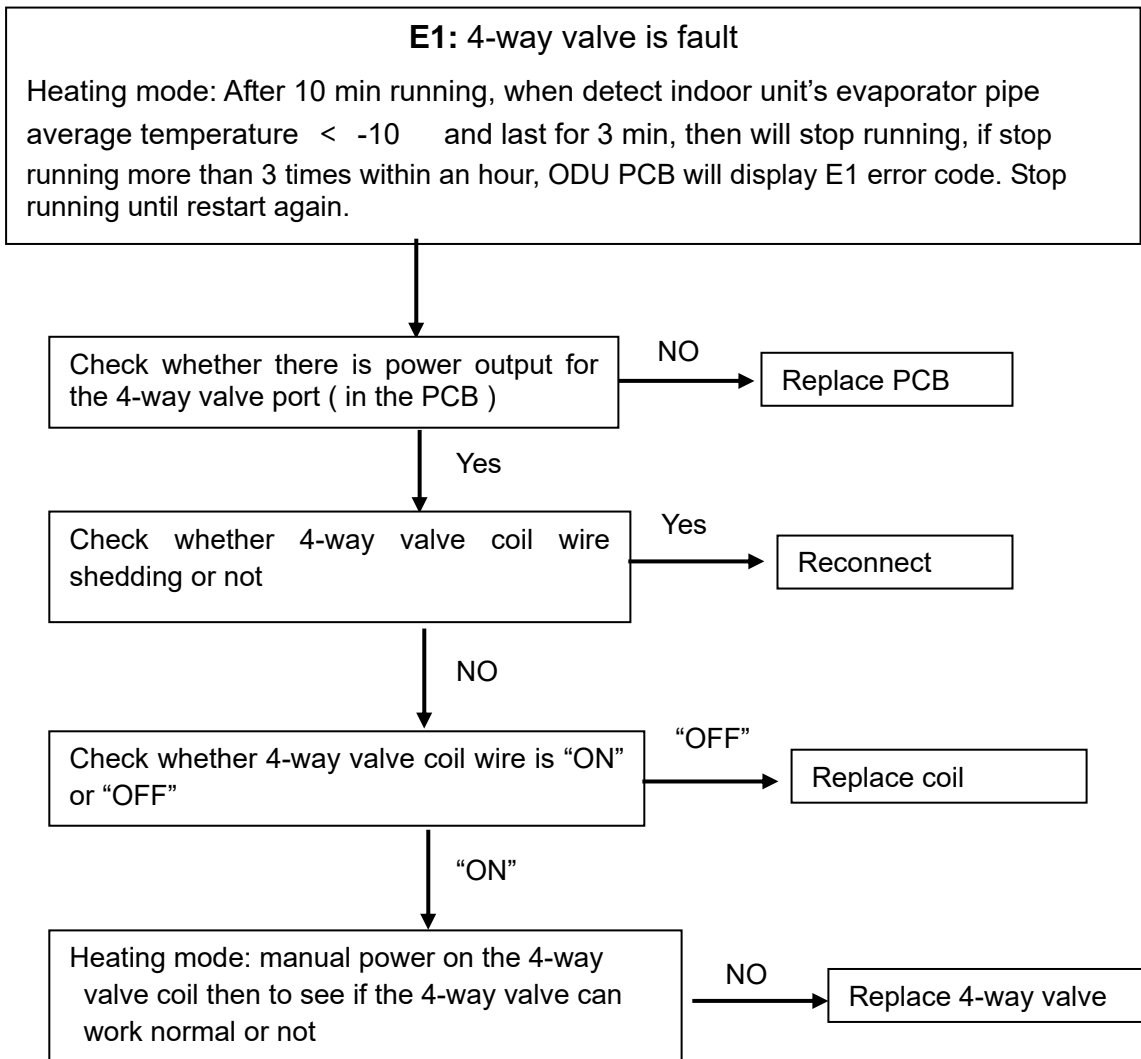

5.5 HJ Error code

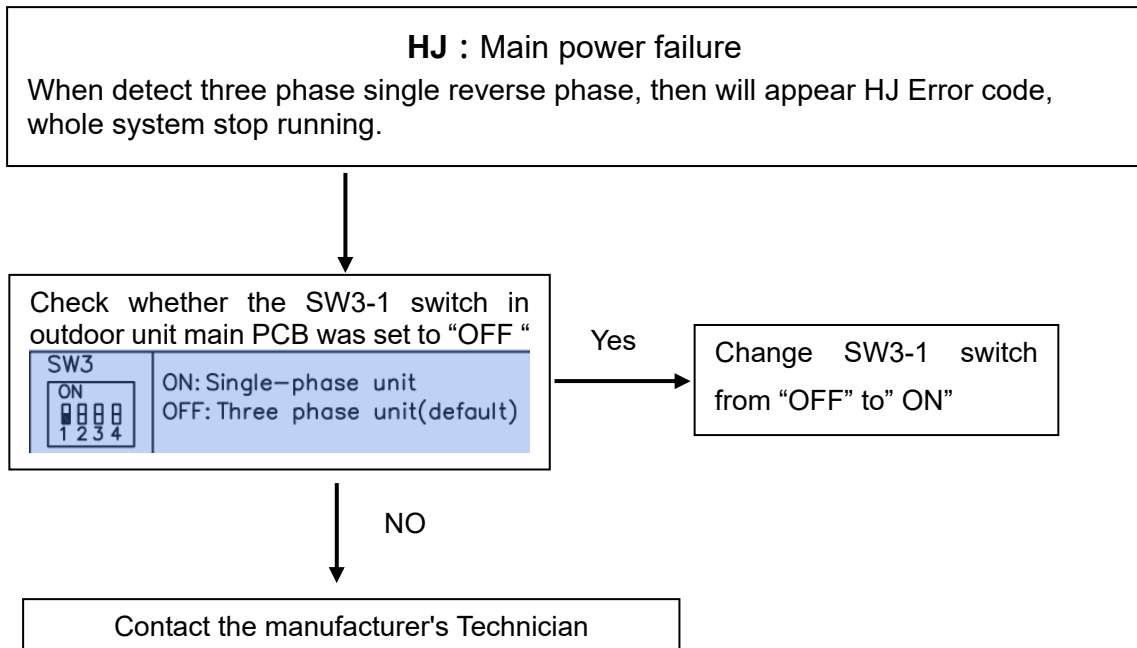

5.6 H5 Error code

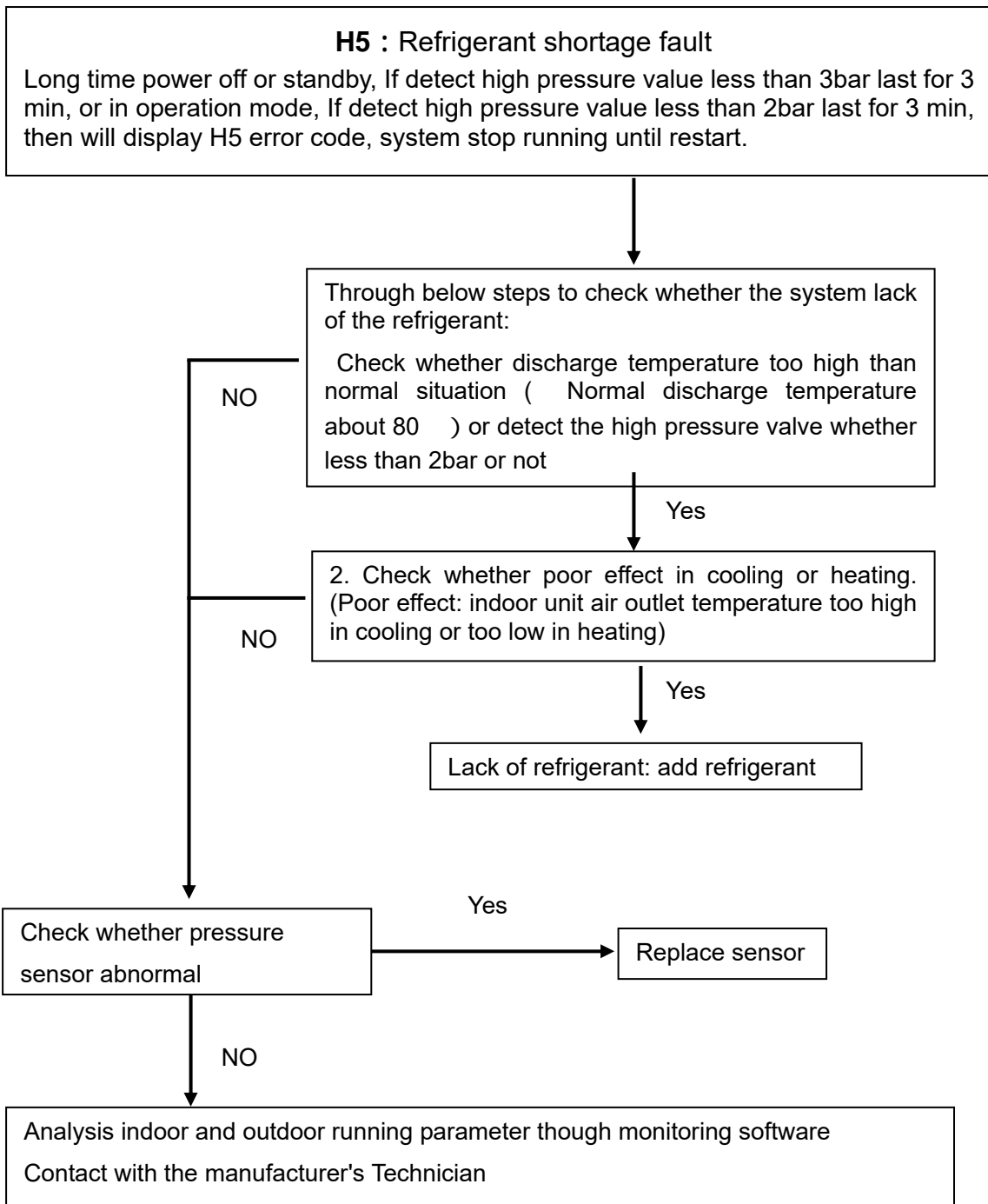

5.7 FH Error code

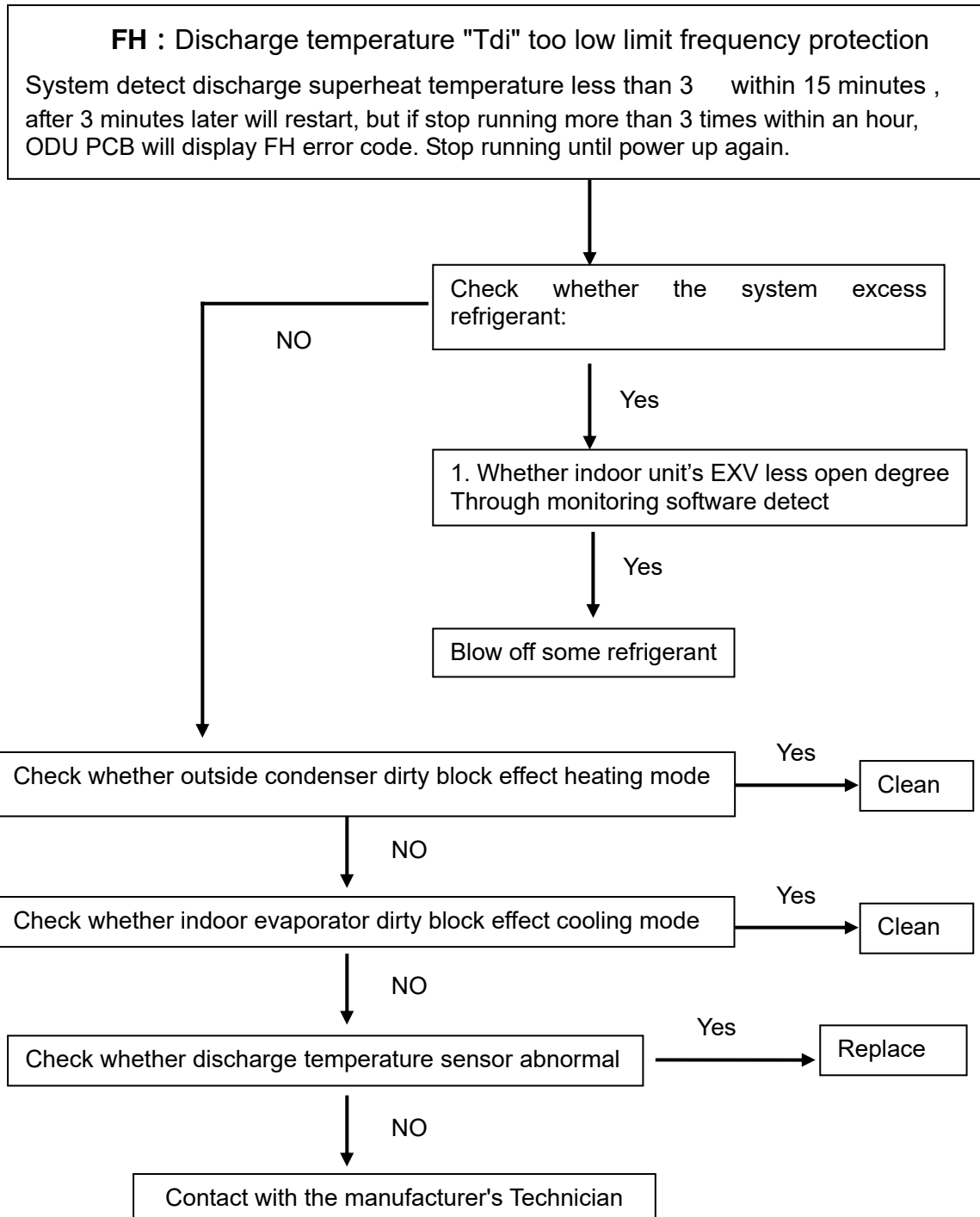

5.8 E3 Error code

**E3** : DC Compressor "Tda" *discharge temperature too high shutdown protection*  
 Detect discharge temperature over than 115 within 10 s , then system will stop running, if stop running more than 3 times within an hour, ODU PCB will display E3 error code. Stop running until restart again.

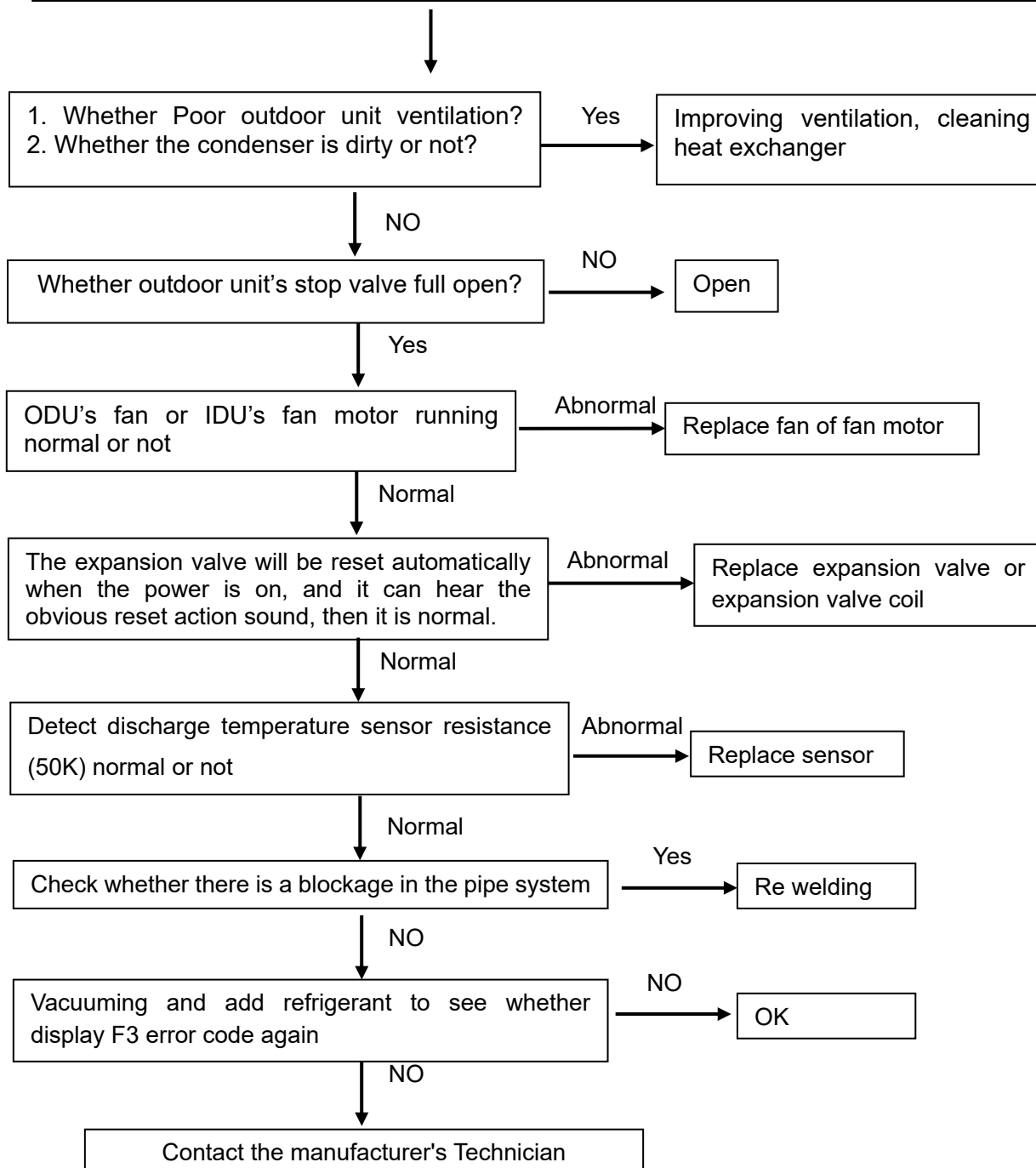

## 3. Appendix

**Relation between temperature sensor of compressor and resistance**

R25=50KΩ±1%			
B25/50=3950K ±1%			
T [ °C ]	Rmin [KΩ]	Rnom [KΩ]	Rmax [KΩ]
-20	449.9	464.7	479.9
-19	425.7	439.5	453.6
-18	402.9	415.7	428.8
-17	381.5	393.4	405.6
-16	361.3	372.3	383.6
-15	342.2	352.5	363.0
-14	324.3	333.9	343.7
-13	307.5	316.4	325.5
-12	291.5	299.8	308.3
-11	276.6	284.3	292.2
-10	262.4	269.6	276.9
-9	249.0	255.7	262.5
-8	236.5	242.7	249.0
-7	224.5	230.3	236.2
-6	213.3	218.7	224.2
-5	202.7	207.7	212.8
-4	192.7	197.3	202.0
-3	183.2	187.5	191.9
-2	174.3	178.3	182.4
-1	165.8	169.5	173.3
0	157.7	161.2	164.7
1	150.2	153.4	156.7
2	142.9	145.9	148.9
3	136.1	138.9	141.7
4	129.7	132.3	134.93
5	123.6	126.0	128.4
6	117.8	120.0	122.3
7	112.2	114.3	116.4
8	107.1	109.0	111.0
9	102.1	103.9	105.7
10	97.42	99.08	100.8
11	92.97	94.51	96.06

12	88.74	90.17	91.61
13	84.73	86.05	87.38
14	80.92	82.14	83.37
15	77.29	78.42	79.56
16	73.84	74.89	75.95
17	70.57	71.54	72.51
18	67.46	68.35	69.25
19	64.49	65.32	66.15
20	61.68	62.44	63.20
21	59.00	59.70	60.40
22	56.44	57.09	57.74
23	54.02	54.61	55.20
24	51.70	52.25	52.80
25	49.50	50.00	50.50
26	47.37	47.87	48.37
27	45.34	45.84	46.34
28	43.41	43.91	44.41
29	41.59	42.08	42.57
30	39.84	40.33	40.82
31	38.18	38.66	39.15
32	36.59	37.07	37.55
33	35.07	35.55	36.03
34	33.64	34.11	34.58
35	32.27	32.73	33.20
36	30.95	31.41	31.87
37	29.70	30.15	30.61
38	28.50	28.95	29.40
39	27.37	27.81	28.25
40	26.29	26.72	27.16
41	25.24	25.67	26.10
42	24.25	24.67	25.09
43	23.31	23.72	24.14
44	22.41	22.81	23.22
45	21.53	21.93	22.33
46	20.71	21.10	21.50
47	19.92	20.30	20.69
48	19.16	19.54	19.92



49	18.44	18.81	19.18
50	17.75	18.11	18.48
51	17.08	17.44	17.80
52	16.44	16.79	17.14
53	15.84	16.18	16.53
54	15.26	15.59	15.93
55	14.69	15.02	15.35
56	14.16	14.48	14.81
57	13.65	13.96	14.28
58	13.15	13.46	13.77
59	12.69	12.99	13.30
60	12.23	12.53	12.83
61	11.80	12.09	12.39
62	11.39	11.67	11.96
63	10.98	11.26	11.54
64	10.60	10.87	11.15
65	10.23	10.50	10.77
66	9.880	10.14	10.41
67	9.537	9.792	10.05
68	9.211	9.460	9.715
69	8.897	9.141	9.391
70	8.595	8.834	9.078
71	8.306	8.539	8.778
72	8.028	8.256	8.490
73	7.759	7.983	8.212
74	7.501	7.720	7.944
75	7.254	7.468	7.687
76	7.016	7.225	7.440
77	6.786	6.991	7.201
78	6.565	6.765	6.971
79	6.352	6.548	6.749
80	6.147	6.339	6.536
81	5.950	6.138	6.331
82	5.761	5.944	6.133
83	5.578	5.757	5.942
84	5.401	5.577	5.758
85	5.231	5.403	5.580

---

86	5.069	5.237	5.410
87	4.912	5.076	5.245
88	4.760	4.921	5.087
89	4.615	4.772	4.934
90	4.474	4.628	4.787
91	4.338	4.489	4.645
92	4.207	4.354	4.506
93	4.081	4.225	4.374
94	3.958	4.099	4.245
95	3.840	3.978	4.121
96	3.726	3.861	4.001
97	3.616	3.748	3.885
98	3.509	3.639	3.773
99	3.407	3.534	3.665
100	3.308	3.432	3.560
101	3.212	3.333	3.459
102	3.119	3.238	3.361
103	3.030	3.146	3.267
104	2.942	3.056	3.174
105	2.858	2.970	3.086
106	2.778	2.887	3.000
107	2.699	2.806	2.917
108	2.623	2.728	2.837
109	2.549	2.652	2.758
110	2.479	2.579	2.683
111	2.410	2.508	2.610
112	2.343	2.439	2.539
113	2.279	2.373	2.471
114	2.216	2.308	2.404
115	2.156	2.246	2.340
116	2.097	2.186	2.278
117	2.040	2.127	2.217
118	1.985	2.070	2.158
119	1.932	2.015	2.102
120	1.880	1.962	2.047

## 更新记录表

No.	version	Updated	Update content
1	20200328 版	阳露	1.删除老版监控软件说明，新版的说明在多联机通用控制器手册体现
2	20200331 版	阳露	1.删除安装部分信息，以研发说明书为准 2.增加电气原理图，修改控制板端口说明 3.修改 3D 爆炸图（所有） 4.增加总体信息&外机数据，整合技术和售后成一本
3	20200416 版	魏文文	1.增加 ARV-H120/SR1DCS7、ARV-H140/SR1DCSA、ARV-H160/SR1DCSA 型号及相关信息
4	20210712 版	解凯	1.增加 ARV-H220/5R1A、ARV-H280/5R1A 型号及相关信息
5	20210722 版	解凯	1 增加部分内机故障代码 2.增加部分外机故障代码
6	20220929 版	解凯	1 增加小多联单风叶机型

